

137.00

A

2731

0

137.00 DEED
1 03/06/84

CONDOMINIUM DECLARATION
FOR
HOLLAND OAKS CONDOMINIUMS
Dallas County, Texas

Unofficial Copy

84046 4400

TABLE OF CONTENTS
FOR THE DECLARATION OF
HOLLAND OAKS CONDOMINIUMS

	<u>Page</u>
INTRODUCTORY	1
ARTICLE I - DEFINITIONS AND TERMS	
Paragraph 1.1 - DEFINITIONS AND TERMS	2
ARTICLE II - CONDOMINIUM UNIT DESIGNATIONS AND DESCRIPTIONS	
Paragraph 2.1 - RECORDATION OF PLAT	
Paragraph 2.2 - DESIGNATION OF UNITS	
Paragraph 2.3 - LIMITED COMMON ELEMENTS	
Paragraph 2.4 - REGULATION OF COMMON AREAS	8
Paragraph 2.5 - INSEPARABLE UNITS	8
Paragraph 2.6 - DESCRIPTIONS	8
Paragraph 2.7 - ENCROACHMENTS	8
Paragraph 2.8 - GOVERNMENTAL ASSESSMENT	9
Paragraph 2.9 - USE AND OCCUPANCY RESTRICTIONS	9
Paragraph 2.10 - RESERVATION OF VARIANCE	15
ARTICLE III - RIGHTS AND OBLIGATIONS OF OWNERSHIP	
Paragraph 3.1 - OWNERSHIP	16
Paragraph 3.2 - PARTITION	16
Paragraph 3.3 - EXCLUSIVENESS OF OWNERSHIP	16
Paragraph 3.4 - ONE-FAMILY RESIDENTIAL DWELLING	16
Paragraph 3.5 - MECHANIC'S AND MATERIALMAN'S LIENS	16
Paragraph 3.6 - RIGHT OF ENTRY	16
Paragraph 3.7 - OWNER MAINTENANCE	17
Paragraph 3.8 - ALTERATION	17
Paragraph 3.9 - RESTRICTION OF OWNERSHIP	17
Paragraph 3.10 - LIABILITY FOR NEGLIGENT ACTS	17
Paragraph 3.11 - SUBJECT TO DECLARATION AND BY-LAWS	18
ARTICLE IV - MANAGEMENT AND ADMINISTRATION	
Paragraph 4.1 - BY-LAWS	18
Paragraph 4.2 - DECLARANT CONTROL	18

	<u>Page</u>
ARTICLE IV - CONTINUED	
Paragraph 4.3 - TEMPORARY MANAGING AGENT	19
Paragraph 4.4 - SPECIFIC POWER TO RESTRICT USE AND ENJOYMENT	19
Paragraph 4.5 - MEMBERSHIP, VOTING, QUORUM, PROXIES	20
Paragraph 4.6 - INSURANCE	21
ARTICLE V - MAINTENANCE ASSESSMENTS	
Paragraph 5.1 - ASSESSMENTS FOR COMMON EXPENSES	23
Paragraph 5.2 - PURPOSE OF ASSESSMENTS	24
Paragraph 5.3 - DETERMINATION OF ASSESSMENTS	24
Paragraph 5.4 - INITIAL ASSESSMENT AND MAXIMUM MONTHLY ASSESSMENT	25
Paragraph 5.5 - SPECIAL ASSESSMENTS FOR IMPROVEMENTS	26
Paragraph 5.6 - COMMENCEMENT OF ASSESSMENTS	26
Paragraph 5.7 - NO EXEMPTION	26
Paragraph 5.8 - LIEN FOR ASSESSMENTS	26
Paragraph 5.9 - SUBORDINATION OF THE LIEN TO MORTGAGES	28
Paragraph 5.10 - STATEMENT OF ASSESSMENTS	28
Paragraph 5.11 - OBLIGATION OF DECLARANT FOR ASSESSMENTS AND MAINTENANCE	29
ARTICLE VI - DESTRUCTION OR OBSOLESCENCE OF IMPROVEMENTS	
Paragraph 6.1 - DESTRUCTION OR OBSOLESCENCE	29
Paragraph 6.2 - JUDICIAL PARTITION	34
Paragraph 6.3 - CONDEMNATION	35
ARTICLE VII - PROTECTION OF MORTGAGEE	
Paragraph 7.1 - NOTICE TO ASSOCIATION	38
Paragraph 7.2 - NOTICE OF DEFAULT; LAPSE IN INSURANCE	38
Paragraph 7.3 - EXAMINATION OF BOOKS	39
Paragraph 7.4 - RESERVE FUND	39
Paragraph 7.5 - ANNUAL AUDITS	39
Paragraph 7.6 - NOTICE OF MEETINGS	39
Paragraph 7.7 - NOTICE OF DAMAGE OR DESTRUCTION	39
Paragraph 7.8 - MANAGEMENT AGREEMENTS	39
Paragraph 7.9 - TAXES, ASSESSMENTS AND CHARGES	40

	<u>Page</u>
ARTICLE VIII - MISCELLANEOUS PROVISIONS	
Paragraph 8.1 - AMENDMENTS TO DECLARATION: APPROVAL OF OWNERS AND MORTGAGEES	40
Paragraph 8.2 - CORRECTION OF ERROR	43
Paragraph 8.3 - OWNERSHIP OF COMMON PERSONAL PROPERTY	43
Paragraph 8.4 - CHANGE IN DOCUMENTS	43
Paragraph 8.5 - NOTICE	43
Paragraph 8.6 - CONFLICT BETWEEN DECLARATION AND BY-LAWS	44
Paragraph 8.7 - INVALIDATION OF PARTS	44
Paragraph 8.8 - OMISSIONS	44
Paragraph 8.9 - TEXAS CONDOMINIUM ACT	44
Paragraph 8.10 - GENDER	44

Unofficial Copy

CONDOMINIUM DECLARATION
FOR
HOLLAND OAKS CONDOMINIUMS

THE STATE OF TEXAS §
COUNTY OF DALLAS §

KNOW ALL MEN BY THESE PRESENTS:

THAT, WHEREAS 3M3 PROPERTIES, INC., a Texas corporation, having its principal office at 9304 Forest Lane, Suite 112, Dallas, Texas, 75243, hereinafter called "Declarant", is the Owner of certain real property situated in the County of Dallas, State of Texas, being described more fully on Exhibit "A", which by this reference is made a part hereof; and

WHEREAS, Declarant desires to establish a Condominium Regime under the Condominium Act of the State of Texas, Title 7, Chapter 81, Texas Property Code, herein called the "Act"; and

WHEREAS, Declarant has prepared plans for the construction of two (2) multifamily Buildings and other improvements appurtenant thereto on the Property described in said Exhibit "A", which when completed shall consist of ten (10) separately designated Condominium Units and which will be known as HOLLAND OAKS CONDOMINIUMS; and

WHEREAS, Declarant does hereby establish a plan for the individual ownership in fee simple of estates consisting of the area or space contained in each of the Units, herein called the "Condominium Regime", in the two (2) Buildings and the co-ownership by the individual and separate Unit Owners thereof, as tenants in common, of all the remaining property, which includes both Limited Common Elements and General Common Elements, as hereinafter defined in Paragraph 1.1 hereof, and which are hereinafter collectively referred to as the "Common Elements" or "Common Areas".

NOW, THEREFORE, Declarant does hereby submit the real property described on the attached Exhibit "A", and all improvements thereon, to the provisions of the Act and the Condominium Regime, and does hereby publish and declare that the following terms, covenants, conditions, easements, restrictions, uses, limitations and obligations shall be deemed to run with the land and shall be a burden and a benefit to Declarant, its successors and assigns and to any person acquiring or owning an interest in the real property and improvements, their grantees, successors, heirs, executors, administrators, devisees and assigns.

84046 4404

ARTICLE I

DEFINITIONS AND TERMS

1.1 DEFINITIONS OF TERMS. As used in this agreement, the following terms shall have the following meanings unless the context shall expressly provide otherwise:

a. "Board" or "Board of Directors" shall refer to the Board of Directors of HOLLAND OAKS OWNERS ASSOCIATION, INC.

b. "Common Assessment" means the charge against each Unit Owner and his Unit, representing a portion of the total costs to the Association of maintaining, improving, repairing, replacing, managing and operating the Property, which are to be paid uniformly by each Unit Owner of the Association, as provided in Paragraph 5.4a herein. This shall also include charges assessed against each Unit Owner to maintain a reserve for replacement fund and to cover costs incurred by the Association to participate in any condemnation suit, as provided in Paragraph 6.3 hereof.

c. "Common Elements" means and includes all of the Property described in Exhibit "A", and all of the improvements thereto and thereon located, excepting all Units. Common Elements shall consist of the General Common Elements and the Limited Common Elements.

d. "Common Expenses" means and includes:

(1) All sums lawfully assessed against the Common Elements by the Managing Agent or Board;

(2) All expenses of administration and management, maintenance, operation, repair or replacement of and addition to the Common Elements (including unpaid special assessments);

(3) Expenses agreed upon as Common Expenses by the Unit Owners; and

(4) Expenses declared to be Common Expenses by this Declaration or by the By-Laws.

e. "Completed Unit" means a completely finished Unit, including, but not limited to, the installation of all appliances and utilities, rendering it ready for occupancy by an Owner other than the Declarant.

84046 4405

f. "Condominium Owners Association" or "Association" means HOLLAND OAKS OWNERS ASSOCIATION, INC., a Texas non-profit corporation, the By-Laws of which shall govern the administration of this Condominium Property and the membership of which shall be composed of all the Owners of the Condominium Units according to such By-Laws.

g. "Condominium Unit" shall mean an individual Unit together with the interest in the Common Elements (General or Limited) appurtenant to such Unit.

h. "Construction Period" means that period of time during which Declarant is developing the Premises and selling the Condominium Units, which time period shall extend from the date hereof until such time as the Declarant transfers title to all of the Condominium Units.

i. "Declarant" shall mean 3M3 PROPERTIES, INC., a Texas corporation, or its successors or assigns, who is developing the Property as a condominium.

j. "Declaration" shall mean this Condominium Declaration instrument.

k. "General Common Elements" means a part of the Common Elements and includes:

(1) The real property described in Exhibit "A" attached hereto, less and except the Units;

(2) All foundations, bearing walls and columns, roofs, halls, lobbies, stairways and entrances and exits or communicationways;

(3) All basements, roofs, yards and gardens, except as otherwise herein provided or stipulated;

(4) All premises for the lodging of janitors or persons in charge of the Buildings, except as otherwise herein provided or stipulated;

(5) All compartments or installations of central services, such as power, light, gas, cold and hot water, refrigeration, central air conditioning and central heating reservoirs, water tanks and pumps, and the like;

84046 4406

(6) All elevators and shafts, garbage incinerators and, in general, all devices or installations existing for common use;

(7) Unassigned parking spaces; and

(8) All other elements of the Buildings desirably or rationally of common use or necessary to the existence, upkeep and safety of the Condominium Regime established by this Declaration.

1. "Lienholder" and "First Mortgagee" shall mean the holder of a first mortgage lien on any Unit in the Condominium Project.

m. "Limited Common Elements" means and includes those Common Elements which are reserved for the exclusive use of an individual Owner of a Unit or a certain number of individual Owners of Units, for the exclusive use of those Owners, which may include:

(1) "Air handlers", pipes, ducts, electrical wiring and conduits located entirely within a Unit or adjoining Units and serving only such Unit or Units, and such portions of the perimeter walls, floors and ceilings, doors, vestibules, windows, entryways, and all associated fixtures and structures therein, and patio structures as lie outside the Unit boundaries; and

(2) Parking spaces designated as an appurtenance to a Unit.

n. "Majority of Unit Owners" means those Owners with fifty-one percent (51%) of the votes entitled to be cast, as weighted as herein provided.

o. "Occupant" means a person or persons in possession of a Unit, regardless of whether said person is a Unit Owner.

p. "Owner" means a person, firm, corporation, partnership, association, trust or other legal entity or any combination thereof, who owns, of record, title to one (1) or more Condominium Units.

q. "Plat", "Survey Map", "Map" and "Plans" mean or include the engineering survey of the land, locating thereon all of the improvements, the floor and elevation plans and any other drawing or diagrammatic plan depicting a part of, or all of, the improvements, same being herewith filed, labeled Exhibit "B" and incorporated herein. It is expressly agreed and each and every Purchaser of a

Unit, his heirs, executors, administrators, assigns and grantees hereby agree that the square footage, size and dimensions of each Unit as set out or shown in this Declaration or in the survey Plats exhibited hereto are approximate and are shown for descriptive purposes only. The Declarant does not warrant, guarantee or represent that any Unit actually contains the area, square footage or dimensions shown by the Plat thereof. Each Purchaser and Owner of a Unit or interest therein agrees that the Unit has been or will be purchased as actually and physically existing at the time such purchase is closed. Each Purchaser of a Unit expressly waives any claim or demand which he may have against the Declarant or any person whosoever on account of any difference, shortage or discrepancy between the Unit as actually and physically existing and as it is shown on the respective Plat thereof exhibited hereto. It is specifically agreed that in interpreting deeds, mortgages, deeds of trust and other instruments for any purposes whatsoever or in connection with any matter, the existing physical boundaries of the Unit shall be conclusively presumed to be the boundaries regardless of settling, rising or lateral movements of the Building, and regardless of variances between boundaries as shown on the Plat and those of the Buildings.

r. "Premises", "Project", or "Property" means and includes the land, the Buildings and all improvements and structures thereon and all rights, easements and appurtenances belonging thereto.

s. "Special Assessments". In addition to the common assessments described above, the Association may levy, in any assessment year, a special assessment applicable to that year only for the purpose of deferring, in whole or in part:

(1) The cost of any construction, reconstruction, repair or replacement of a capital improvement upon the Common Area, including fixtures and personal property related thereto; or

(2) The expense of any other contingencies or unbudgeted costs; provided that any such assessment shall have the assent of two-thirds (2/3) of the votes of the Members who are voting in person or by proxy at a meeting

84046 4408

duly called for this purpose. Any amounts assessed pursuant hereto shall be assessed to Owners in proportion to the interest in the Common Elements owned by each. The Association, after due notice and hearing, shall also have the authority to establish and fix a special assessment upon any Unit to secure the liability of the Owner of such Unit to the Association for any breach by such Owner of any of the provisions of this Declaration, which breach shall require an expenditure by the Association for repair or remedy. Special assessments may be billed or collected on a monthly basis. The above mentioned liability of any Owner is to be established as set forth in this Declaration.

t. "Unit" shall mean the elements of an individual Condominium Unit which are not owned in common with the Owners of the other Condominium Units in the Project as shown on the Maps, which are exhibits attached hereto, and each Unit shall include the air space assigned thereto. The boundaries of each such Unit shall be and are the interior surfaces of the perimeter walls, floors, ceilings, window frames, doors, door frames and trim, and exterior surfaces of the patios, and the space includes both the portions of the Building so described and the air space so encompassed, excepting the Common Elements. In interpreting deeds, mortgages, deeds of trust and other instruments, the existing physical boundaries of the Unit reconstructed in substantial accordance with the original plans thereof shall be conclusively presumed to be its boundaries, regardless of settling, rising or lateral movement of the Building and regardless of variances between boundaries shown on the Plat and those of the Building. The individual ownership of each Unit space herein defined shall further include the interior construction, partitions, appliances, fixtures and improvements which are intended to exclusively serve such Unit space, such as interior room walls, floor coverings or finish, closets, cabinets, shelving, individual bathroom and kitchen fixtures, plumbing and appliances, individual lighting and electrical fixtures and other separate items or chattels belonging exclusively to such Unit, any

84046 4409

of which may be removed, replaced, disposed of or otherwise treated without affecting any other Unit space or ownership, use or enjoyment thereof. None of the land in this Project on which any Unit space or porch space is located shall be separately owned, as all land in this Project shall constitute part of the "Common Elements" of the Property as herein defined, and shall be owned in common by the Owners of the Units in this Condominium Project. It is intended the term "Unit", as used in this Declaration, shall have the same meaning as the term "Apartment" as used in the Act.

ARTICLE II

CONDOMINIUM UNIT DESIGNATIONS AND DESCRIPTIONS

2.1 RECORDATION OF PLAT. The Plat shall be filed for record simultaneously with the recording of this Declaration as a part hereof, and prior to the first conveyance of any Condominium Unit. Such Plat consists of and sets forth:

- a. The legal description of the surface of the land;
- b. The linear measurements and location, with reference to the exterior boundaries of the land, of the Buildings and all other improvements constructed, or to be constructed, on said land by Declarant;
- c. The exterior boundaries and number of each Unit, expressing its square footage, and any other data necessary for its identification, which information will be depicted by a Plat of such floor of each Building showing the letter of the Building, the number of the floor and the number of the Unit; and
- d. The location of the Limited Common Elements.

2.2 DESIGNATION OF UNITS. The Property is hereby divided into ten (10) separately designated Units contained within the two (2) Buildings. Each Unit is identified by number and each Building is identified by letter on the Map. The remaining portion of the Premises, referred to as the Common Elements, shall be owned in common by the Owners. The Owners of each Unit shall own an undivided interest in said Common Elements, the percentage or fraction thereof for each Unit being as shown on the attached Exhibit "C".

2.3 LIMITED COMMON ELEMENTS. Portions of the Common Elements are set aside and reserved for the exclusive use of the individual Owners, such areas

84046 4410

being Limited Common Elements. The Limited Common Elements reserved for the exclusive use of the individual Owners are the assigned automobile parking spaces and patio structures. Such spaces and structures are allocated and assigned by the Declarant to the respective Units, as indicated on the Plat. Such Limited Common Elements shall be used in connection with the particular Unit, to the exclusion of the use thereof by the other Owners, except by invitation.

2.4 REGULATION OF COMMON AREAS. Portions of the Common Areas are intended as recreation areas, and are improved with green areas and other facilities. Reasonable regulations governing the use of such facilities by Owners and by their guests and invitees shall be promulgated by the Declarant, or by the Board of Directors of the Association after the same has been elected. Such regulations shall be permanently posted at the office and/or elsewhere in said recreational areas, and all Owners shall be furnished with a copy thereof. Each Owner shall be required to strictly comply with said Rules and Regulations, and shall be responsible to the Association for the compliance therewith by the members of their respective families, relatives, guests or invitees, both minor and adult.

2.5 INSEPARABLE UNITS. Each Unit and its corresponding pro-rata interest in and to the Common Elements appurtenant thereto shall be inseparable and may not be conveyed, leased or encumbered separately, and shall at all times remain indivisible.

2.6 DESCRIPTIONS. Every deed, lease, mortgage, trust deed or other instrument may legally describe a Condominium Unit by its identifying Building letter and Unit number, as shown on the Map, followed by the words HOLLAND OAKS CONDOMINIUMS and by reference to this recorded Declaration and Map. Every such description shall be deemed good and sufficient for all purposes to convey, transfer, encumber or otherwise affect the Common Elements.

2.7 ENCROACHMENTS. If any portion of the Common Elements encroaches upon a Unit or Units, a valid easement for the encroachment and for the maintenance of same, so long as it stands, shall and does exist. If any portion or portions of a Unit or Units encroach upon the Common Elements, a valid easement for the encroachment and for the maintenance of same, so long as it stands, shall and does exist. A valid easement also exists to that portion of the General Common Elements and of the Limited Common Elements occupied by any part of an Owner's Unit not contained within the physical

boundaries of such Unit, including, but not limited to, space occupied by heating and air conditioning equipment, utility lines and similar equipment which serves only one (1) Unit. For title or other purposes, such encroachments and easements shall not be considered or determined to be encumbrances either on the Common Elements or the individual Units.

2.8 GOVERNMENTAL ASSESSMENT. Declarant shall give written notice to the Assessor's Office of the creation of Condominium Ownership of this Property, as is provided by law, so that each Unit and its percentage or fraction of undivided interest in the Common Elements shall be deemed a separate parcel and subject to separate assessment and taxation.

2.9 USE AND OCCUPANCY RESTRICTIONS.

a. Subject to the provisions of this Declaration and By-Laws, no part of the Property may be used for purposes other than housing and the related common purposes for which the Property was designed. Each Unit or any two (2) or more adjoining Units used together shall be used for residential purposes or such other uses permitted by this Declaration, and for no other purposes. The foregoing restrictions as to residence shall not, however, be construed in such manner as to prohibit a Unit Owner from:

- (1) Maintaining his personal professional library;
- (2) Keeping his personal business or professional records or accounts; or
- (3) Handling his personal business or professional telephone calls or correspondence, which uses are expressly declared customarily incidental to the principal residential use and not in violation of said restrictions.

b. That part of the Common Elements separating and located between and exclusively serving two (2) or more adjacent Units used together (including, without limitation, portions of any hallway and any walls) may be altered with written consent of the Board, as provided in Paragraph 3.8 herein, to afford ingress to and egress from such Units and to afford privacy to the Occupants of such Units when using such Common Elements, and that part of the Common Elements so altered may be used by the Unit Owner or Owners of such Units as a licensee pursuant to a license agreement with the Association, provided:

84046 4412

(1) The expense of making such alterations shall be paid in full by the Unit Owner or Owners making such alterations;

(2) Such Unit Owner or Owners shall pay in full the expense of restoring such Common Elements to their condition prior to such alteration in the event such Units shall cease to be used together, as aforesaid; and

(3) Such alteration shall not interfere with use and enjoyment of the Common Elements (other than the aforesaid part of the Common Elements separating such adjacent Units), including, without limitation, reasonable access and ingress to and egress from the other Units in the hallway affected by such alteration.

c. The Common Elements shall be used only by the Unit Owners and their agents, servants, tenants, family members, customers, invitees and licensees for access, ingress to and egress from the respective Units and for other purposes incidental to use of the Units; provided, however, receiving rooms, and any other areas designed for specific use shall be used for the purposes approved by the Board.

d. The use, maintenance and operations of the Common Elements shall not be obstructed, damaged or unreasonably interfered with by any Unit Owner, and may be subject to lease, concession or easement, presently in existence or entered into by the Board at some future time.

e. Without limiting the generality of the foregoing provisions of this Paragraph 2.9, use of the Property by the Unit Owners shall be subject to the following restrictions:

(1) Nothing shall be stored in the Common Elements without prior consent of the Board, except in storage areas or as otherwise herein expressly provided;

(2) Nothing shall be done or kept in any Unit or in the Common Elements which will increase the rate of insurance for the Property without the prior written consent of the Board. No Unit Owner shall permit anything to be done or kept in his Unit or the Common Elements

84046 4413

which will result in the cancellation of insurance on any Unit, or any part of the Common Elements, or which will be in violation of any law;

(3) No waste shall be committed in or on the Common Elements;

(4) Subject to Declarant's rights under Paragraph 2.9e(14)(d) of this Declaration, no sign of any kind shall be displayed to the public view on or from any Unit or Common Elements without the prior written consent of the Board or the written consent of the Managing Agent acting in accord with the Board's direction;

(5) No noxious or offensive activity shall be carried on, in or upon the Common Elements, nor shall anything be done therein which may be or become an unreasonable annoyance or a nuisance to any other Unit Owner. No loud noises or noxious odors shall be permitted on the Property, and the Board shall have the right to determine in accordance with the By-Laws if any such noise, odor or activity constitutes a nuisance. Without limiting the generality of any of the foregoing provisions, no exterior speakers, horns, whistles, bells or other sound devices (other than security devices used exclusively for security purposes), noisy or smoky vehicles, large power equipment or large power tools, unlicensed off-road motor vehicles or other items which may unreasonably interfere with television or radio reception of any Unit Owner in the Property, shall be located, used or placed on any portion of the Property or exposed to the view of other Unit Owners without the prior written approval of the Board;

(6) Except as expressly provided hereinabove, nothing shall be altered or constructed in or removed from the Common Elements, except upon the written consent of the Board;

(7) No structure of a temporary character, trailer, tent, shack, garage, barn or other outbuildings shall be

84046 4414

permitted on the Property at any time temporarily or permanently, except with the prior written consent of the Board; provided, however, that temporary structures may be erected for use in connection with the repair or rebuilding of the Buildings or any portion thereof;

(8) No rubbish, trash or garbage or other waste material shall be kept or permitted upon any Unit or the Common Elements, except in sanitary containers located in appropriate areas screened and concealed from view, and no odor shall be permitted to arise therefrom so as to render the Property or any portion thereof unsanitary, unsightly, offensive or detrimental to any other Property in the vicinity thereof or to its Occupants. There shall be no exterior fires whatsoever except barbecue fires contained within receptacles designed in such a manner that no fire hazard is created. No clothing or household fabrics shall be hung, dried or aired in such a way in the Property as to be visible to other Property and no lumber, grass, shrub or tree clippings, plant waste, metals, bulk material, scrap, refuse or trash shall be kept, stored or allowed to accumulate on any portion of the Property, except within an enclosed structure or if appropriately screened from view;

(9) No Unit Owner shall park, store or keep any vehicle, except wholly within the parking space designated therefor, and any inoperable vehicle shall not be stored in a parking space or within the Common Elements in general. No Unit Owner shall park, store or keep within or adjoining the Property any large commercial-type vehicle (dump truck, cement-mixer truck, oil or gas truck, delivery truck and any other vehicle equipment, mobile or otherwise, deemed to be a nuisance by the Board), or any recreational vehicle (camper unit, motor home, truck, trailer, boat, mobile home or other similar vehicle deemed to be a nuisance by the Board). No Unit Owner shall conduct major repairs or major restorations of any motor

84046 4415

vehicle, boat, trailer, aircraft or other vehicle upon any portion of the Common Elements. Parking spaces shall be used for parking purposes only;

(10) Except within individual Units, no planting, transplanting or gardening shall be done, and no fences, hedges or walls shall be erected or maintained upon the Property, except as approved by the Board;

(11) Motorcycles, motorbikes, motor scooters or other similar vehicles shall not be operated within the Property except for the purpose of transportation directly from a parking space to a point outside the Property, or from a point outside the Property directly to a parking space;

(12) No animals, livestock, reptiles, or poultry of any kind shall be raised, bred or kept in any Unit or the Common Elements. Dogs, cats, fish, birds and other household pets may be kept in Units subject to rules and regulations adopted by the Association, provided they are not kept, bred or maintained for commercial purposes or in unreasonable quantities. As used in this Declaration, "unreasonable quantities" shall ordinarily mean more than two (2) pets per household; provided, however, the Association may determine a reasonable number in any instance to be more or less, and the Association may limit the size and weight of any household pets allowed. The Association, acting through the Board, shall have the right to prohibit maintenance of any animal which constitutes, in the opinion of the Board, a nuisance to any other Unit Owner. Animals belonging to Unit Owners, Occupants or their licensees, tenants or invitees within the Property must be kept either within an enclosure, an enclosed patio or on a leash being held by a person capable of controlling the animal. The enclosure must be so maintained that the animal cannot escape therefrom and shall be subject to the approval of the Board. Should any animal belonging to a Unit Owner be found unattended out of the enclosure and not being held on a leash by a person

capable of controlling the animal, such animal may be removed by Declarant (for so long as it has control over the Association) or a person designated by Declarant to do so, and subsequent thereto by the Association or its Managing Agent, to a pound under the jurisdiction of the local municipality in which the Property is situated and subject to the laws and rules governing said pound, or to a comparable animal shelter. Furthermore, any Unit Owner shall be absolutely liable to each and all remaining Unit Owners, their families, guests, tenants and invitees, for any unreasonable noise or damage to person or property caused by any animals brought or kept upon the Property by a Unit Owner or members of his family, his tenants or his guests; and it shall be the absolute duty and responsibility of each such Unit Owner to clean up after such animals which have used any portion of the Common Elements;

(13) No Unit Owner shall be permitted to lease his Unit for hotel or transient purposes, which, for purposes of this paragraph is defined as a period less than thirty (30) days. No Unit Owner shall be permitted to lease less than the entire Unit. Every such lease shall be in writing. Every such lease shall provide that the lessee shall be bound by and subject to all of the obligations under the Declaration and By-Laws, of the Unit Owner making such lease and failure to do so shall be a default thereunder. The Unit Owner making such lease shall not be relieved thereby from any of said obligations; and

(14) In order that Declarant may establish the Property as a fully occupied Condominium, no Unit Owner nor the Association shall do anything to interfere with, and nothing in the Declaration shall be understood or construed to:

(a) Prevent Declarant, its successors or assigns, or its or their contractors or subcontractors, from doing in any Unit owned by

84046 4417

them whatever they determine to be necessary or advisable in connection with the completion of any work thereon;

(b) Prevent Declarant, its successors or assigns, or its or their representatives, from erecting, constructing and maintaining on the Common Elements or any Unit owned or controlled by Declarant, its successors or assigns, or its or their contractors or subcontractors, such structures as may be reasonably necessary for the conduct of its or their business of completing any work and establishing the Property as a Condominium and disposing of the same by sale, lease or otherwise;

(c) Prevent Declarant, its successors or assigns, or its or their representatives, from maintaining a Sales Office and maintaining and showing model Units to aid in the marketing of the Units during the Construction Period; or

(d) Prevent Declarant, its successors or assigns, or its or their contractors or subcontractors, from maintaining such sign or signs for marketing of Units in the Property.

2.10 RESERVATION OF VARIANCE. Notwithstanding any provision of this Declaration to the contrary, the Declarant reserves unto itself the exclusive right to amend the Condominium Plat and to vary the size, shape, physical lay-out or location of the unsold Units and to correspondingly adjust the sales price and the percentage or fraction of ownership of the Common Elements or the respective Units remaining unsold. Such adjustment in the percentage or fraction of ownership of the Common Elements will only affect those Units owned by the Declarant, and will not change or affect the percentage or fraction of ownership of any other Unit. This reservation shall not work to readjust or reallocate any vested interests in the Common Elements appurtenant to any sold Units.

84046 4418

ARTICLE III

RIGHTS AND OBLIGATIONS OF OWNERSHIP

3.1 OWNERSHIP. A Condominium Unit will be a fee simple estate and may be held and owned by any person, firm, corporation or other entity singularly, as joint tenants, as tenants in common, or in any real property tenancy relationship recognized under the laws of the State of Texas.

3.2 PARTITION. The Common Elements (both General and Limited) shall be owned in common by all of the Owners of the Condominium Units and shall remain undivided, and no Owner shall bring any action for partition or division of the Common Elements other than that as specifically provided for hereinafter in Paragraph 6.2, "Judicial Partition", and, in any event, all mortgages must be paid prior to the bringing of an action for partition or the consent of all Mortgagees must be obtained. Nothing contained herein shall be construed as limitation of the right of partition of a Condominium Unit between the Owners thereof, but such partition shall not affect any other Condominium Unit.

3.3 EXCLUSIVENESS OF OWNERSHIP. Each Owner shall be entitled to exclusive ownership and possession of his Unit. Each Owner may use the Common Elements in accordance with the purposes for which they are intended, without hindering or encroaching upon the lawful rights of the other Owners.

3.4 ONE-FAMILY RESIDENTIAL DWELLING. Each Condominium Unit shall be occupied and used or leased by the Owner only as and for a residential dwelling for the Owner, his family, his social guests or his tenants.

3.5 MECHANIC'S AND MATERIALMAN'S LIENS. No labor performed or materials furnished and incorporated in a Unit, notwithstanding the consent or request of the Owner, his agent, contractor or subcontractor, shall be the basis for filing of a lien against the Common Elements owned by such other Owners. Each Owner shall indemnify and hold harmless each of the other Owners from and against all liability arising from the claim of any lien against the Unit of any other Owner or against the Common Elements for construction performed or for labor, materials, services or other products incorporated in the Owner's Unit at such Owner's request.

3.6 RIGHT OF ENTRY. The Association shall have the irrevocable right to have access to each Unit from time to time during reasonable hours as may be necessary for the maintenance, repair or replacement of any of the Common Elements therein or accessible therefrom, or at any time for making emergency repairs therein necessary to prevent damage to the Common Elements or to another Unit or Units.

84046 4419

3.7 OWNER MAINTENANCE. An Owner shall maintain and keep in repair the interior and patio space of his own Unit, including the fixtures thereof. All fixtures and equipment installed with the Unit, commencing at a point where the utility lines, pipes, wires, conduits or systems (which for brevity are hereafter referred to as "utilities") enter the Unit, shall be maintained and kept in repair by the Owner thereof; and an Owner shall be obliged to promptly repair and replace any broken or cracked glass in windows and doors. An Owner shall be totally responsible for his own heating and cooling system.

3.8 ALTERATION. An Owner shall do no act nor any work that will impair the structural soundness and integrity of the Building or impair any easement or hereditament. No Owner shall in any way alter, modify, add to or otherwise perform any work whatever upon any of the Common Elements, Limited or General, without the prior written consent and approval in writing by the Board of Directors. Any such alteration or modification shall be in harmony with the external design and location of the surrounding structures and topography, and shall not be considered until submission to the Association of complete plans and specifications showing the nature, kind, shape, size, materials, color and location for all proposed work. The Board shall have the obligation to answer within thirty (30) days after receipt of notice of the proposed alterations. Failure to so answer within the stipulated time shall mean that there is no objection to the proposed alteration or modification. During the Construction Period, Declarant shall have the sole right to approve or reject any plans and specifications submitted for consideration by an Owner.

3.9 RESTRICTION OF OWNERSHIP. As a restriction of the ownership provisions set forth in Paragraph 1.1t, "Unit", an Owner shall not be deemed to own the unfinished surfaces of the perimeter walls, floors, ceilings, balconies, patios and roofs surrounding his Unit, nor shall such Owner be deemed to own the utilities running through his Unit which are utilized for, or serve, more than one (1) Unit, except as a tenant in common with the other Owners. An Owner shall be deemed to own and shall maintain the inner, finished surfaces of the perimeter and interior walls, floors and ceilings, doors, windows and other such elements consisting of paint, wallpaper and other such finishing material.

3.10 LIABILITY FOR NEGLIGENT ACTS. In the event the need for maintenance or repair is caused through the willful or negligent act of an Owner, his family, guests or invitees, and is not covered or paid for by insurance either

on such Unit or the Common Elements, the cost of such maintenance or repairs shall be added to and become a part of the assessment to which such Unit is subject, pursuant to Article IV hereof. Such liability is limited to the liability Owner has under Texas law.

3.11 SUBJECT TO DECLARATION AND BY-LAWS. Each Owner and the Association shall comply strictly with the provisions of this Declaration, the By-Laws and the decisions and resolutions of the Association adopted pursuant thereto, as the same may be lawfully amended from time to time. Failure to comply with any of the same shall be grounds for an action to recover sums due for damages or for injunctive relief, or both, maintainable by the Association on behalf of the Owners or, in proper case, by an aggrieved Owner against another Owner or against the Association.

ARTICLE IV

MANAGEMENT AND ADMINISTRATION

4.1 BY-LAWS. The administration of this Condominium Property shall be governed by the By-Laws of HOLLAND OAKS OWNERS ASSOCIATION, INC., a non-profit corporation, referred to herein as the "Association". An Owner of a Condominium Unit, upon becoming an Owner, shall be a Member of the Association and shall remain a Member for the period of his ownership. The Association may be managed by a Board of Directors, duly appointed or elected, pursuant to the terms and conditions of the By-Laws. In addition, the Association shall enter into a management agreement upon the terms and conditions established in the By-Laws, and said management agreement shall be consistent with this Declaration.

4.2 DECLARANT CONTROL. Paragraph 4.1 notwithstanding, and for the benefit and protection of the Unit Owners and any First Mortgagees of record for the sole purpose of insuring a complete and orderly buildout as well as a timely sellout of the Condominium Project, the Declarant will retain control of and over the Association for a maximum period not to exceed March 1, 1986, or one hundred twenty (120) days from the closing of sales of seventy-five percent (75%) of the Units, or when in the sole opinion of the Declarant, the Project becomes viable, self-supporting and operational, whichever occurs first. It is expressly understood, the Declarant will not use said control for any advantage over the Unit Owners by way of retention of any residual rights or interests in the Association or through the creation of any

84046 4421

management agreement with a term longer than three (3) years without majority Association approval upon relinquishment of Declarant control. Within sixty (60) days from the end of the Declarant Control Period, or sooner at the Declarant's option, the Declarant, through the Board of Directors, shall call the first annual meeting of the Association for the purpose of electing, by ballot of Owners, a Board of Directors and to transact such other business of the Association as may properly come before it.

4.3 TEMPORARY MANAGING AGENT. During the period of administration of this Condominium Regime by Declarant, the Declarant may employ or designate a temporary manager or managing agent, who shall have and possess all of the rights, powers, authority, functions and duties as may be specified in the contract of employment or as may be delegated by Declarant to him. The Declarant may pay such temporary manager or managing agent such compensation as it may deem reasonable for the services to be rendered, which compensation shall constitute a part of the Common Expenses of this Condominium Regime and shall be paid out of the Association budget.

4.4 SPECIFIC POWER TO RESTRICT USE AND ENJOYMENT. Every Owner and the Declarant shall have a beneficial interest of use and enjoyment in the Common Elements subject to the following limitations, restrictions and provisions:

a. The right of the Association to publish rules and regulations governing use of the Common Areas and the improvements and facilities located thereon, and to establish and enforce penalties for infractions thereof;

b. The right of the Association to charge reasonable fees for the use of the Common Elements, if such facilities are not used by all Members equally;

c. The right of the Association to borrow money and mortgage the Common Area and improvements for the purpose of improving the Common Area and facilities and in aid thereof to mortgage said property; providing, however, that the rights of any such Mortgagee in such property shall be subordinate to the rights of the Owners hereunder, and in no event shall any such Mortgagee have the right to terminate the Condominium Regime established by this Declaration;

d. The right and duty of the Association to suspend the voting rights and the right to the use of the recreational facilities by an Owner for any period during which any assessment against the Owner's Condominium Unit remains unpaid;

84046 4422

e. The right of Declarant or the Association after the Declarant Control Period to dedicate or transfer all or any part of the Common Area for utility easements to any public agency, authority or utility for the purposes, and subject to the conditions, of such agency, authority or utility. No such dedication or transfer shall be effective unless approved by all First Mortgagees and two-thirds (2/3) vote of the quorum of Owners present at a meeting of the Association specifically called for the purpose of approving any such dedication or transfer, and unless an instrument signed by the Board of Directors reflecting such vote of the Owners agreeing to such dedication or transfer and First Mortgagee approval has been duly recorded in the Condominium Records of Dallas County, Texas;

f. The right of the Association to adopt, implement and maintain a private security system for the Premises consistent with applicable laws;

g. The right of the Association to establish rules and regulations governing traffic within the Common Area, and to establish sanctions for any violation or violations of such rules and regulations;

h. The right of the Association to regulate noise within the Premises, including, without limitation, the right of the Association to require mufflers on engines and to prohibit the use of devices producing excessive noise; and

i. The right of the Association to control the visual attractiveness of the property, including, without limitation, the right to require Owners to eliminate objects which are visible from the Common Area and which, in the Association's judgment, detract from the visual attractiveness of the Property.

4.5 MEMBERSHIP, VOTING, QUORUM, PROXIES.

a. Membership. Any person on becoming an Owner of a Condominium Unit shall automatically become a Member of the Association. Such membership shall terminate without any formal Association action whenever such person ceases to own a Condominium Unit, but such termination shall not relieve or release any such former Owner from any liability or obligation incurred under or in

84046 4423

any way connected with HOLLAND OAKS CONDOMINIUMS during the period of such ownership and membership of the Association, or impair any rights or remedies which the Board of Directors of the Association or others may have against such former Owner and Member arising out of or in any way connected with such ownership and membership and the covenants and obligations incident thereto. No certificates of stock shall be issued by the Association, but the Board of Directors may, if it so elects, issue one (1) membership card to the Owner(s) of a Condominium Unit. Such membership card shall be surrendered to the Secretary whenever ownership of the Condominium Unit designated thereon shall terminate.

b. Voting. Unit ownership shall entitle the Owner(s) to cast one (1) vote per Unit in the affairs of the Association, which vote will be weighted to equal the proportionate share of ownership of the Unit Owner in the Common Elements. Voting shall not be split among more than one (1) Unit Owner. The present number of votes that can be cast by the Unit Owners is ten (10). The combined weighted votes calculated in accordance with Exhibit "C" shall equal one hundred percent (100%).

c. Quorum. The majority of the Unit Owners as defined in Article I shall constitute a quorum.

d. Proxies. Votes may be cast in person or by proxy. Proxies may be filed with the Secretary before the appointed time of each meeting.

4.6 INSURANCE.

a. The Association shall obtain and maintain at all times insurance of the type and kind provided hereinafter, including such other risks, of a similar or dissimilar nature, as are or shall hereafter customarily be covered with respect to any Condominium Buildings, fixtures, equipment and personal property, similar in construction, design and use, issued by responsible insurance companies authorized to do business in the State of Texas. The insurance shall be carried in blanket policy form naming the Association and all Mortgagees as the insured. In addition, each policy or policies shall identify the interest of each Condominium Unit Owner and shall provide for a standard, noncontributory

84046 4424

mortgage clause in favor of each First Mortgagee. Further, the policy shall insure against loss or damage by fire, vandalism, malicious mischief or such other hazards as are covered under standard extended coverage provisions for the full insurable replacement cost of the Common Elements and the Units, and against such other hazards and for such amounts as the Board may deem advisable. Each Owner irrevocably designates the Owners Association, as Attorney In Fact, to administer and distribute such proceeds as is elsewhere provided in this Declaration. Such insurance policy shall also provide that it cannot be cancelled by either the insured or the insurance company until after thirty (30) days prior written notice to each First Mortgagee. The Board of Directors shall, upon request of any First Mortgagee, furnish a certified copy of each blanket policy and a separate certificate identifying the interest of the Mortgagor.

b. The Association shall keep a comprehensive policy or policies of public liability insurance covering the Common Elements of the Project with a contractual liability endorsement, and such policy or policies shall include a "Severability of Interest Endorsement" or equivalent coverage which will preclude the insurer from denying the claim of a Unit Owner because of negligent acts by the Association, its Board of Directors or a Unit Owner. Such policy or policies shall be in amounts of not less than One Hundred Thousand Dollars (\$100,000.00) per person, Three Hundred Thousand Dollars (\$300,000.00) per accident and Fifty Thousand Dollars (\$50,000.00) property damage, plus an umbrella policy for not less than One Million Dollars (\$1,000,000.00) for all claims for personal injury, including death, and/or property damage arising out of a single occurrence; and the policy shall include water damage liability, liability for non-owned and hired automobiles, liability for property of others and such other coverage as is customarily deemed necessary with respect to projects similar in nature.

c. The Association shall keep a policy or policies of (i) liability insurance insuring the Board of Directors, officers and employees of the Association against any claims, losses,

84046 4425

liabilities, damages or causes of action arising out of, or in connection with, or resulting from any act done or omission to act by any such person or entities, (ii) workmen's compensation as required under the laws of the State of Texas, and (iii) such other insurance as deemed reasonable and necessary in order to protect the Project, the Unit Owners and the Association.

d. The Association shall be responsible for obtaining insurance upon the Units, including all fixtures, installations or additions thereto contained within the unfinished interior surfaces of the perimeter walls, floors and ceilings of such Unit, as initially installed or replacements thereof. The Association shall not be responsible for procurement or maintenance of any insurance covering the liability of any Unit Owner not caused by or connected with the Association's operation or maintenance of the Project. Each Unit Owner may obtain additional insurance at his own expense for his own benefit. Insurance coverage on the furnishings and other items of personal property belonging to a Unit Owner and casualty and public liability insurance coverage within each Unit are specifically made the responsibility of each Unit Owner, and each Unit Owner must furnish a copy of his insurance policy to the Association.

e. The Association shall obtain fidelity bond coverage as provided in Paragraph 5.12 of the By-Laws.

f. Any insurance obtained by the Association or a Unit Owner shall contain appropriate provisions whereby the insurer waives its right of subrogation as to any claims against the Unit Owners, Association or their respective servants, agents or guests.

ARTICLE V

MAINTENANCE ASSESSMENTS

5.1 ASSESSMENTS FOR COMMON EXPENSES. All Owners shall be obligated to pay the assessments imposed by the Association to meet the Common Expenses. Assessments for the estimated Common Expenses shall be due monthly in advance on or before the first day of each month. Failure to pay by the fifteenth (15th) day of each month shall require the imposition and assessment of a late charge to be set by the Board of Directors in the Rules and Regulations of the

84046 4426

Association. Contribution for monthly assessments shall be prorated if the ownership of a Condominium Unit commences on a day other than the first day of the month.

5.2 PURPOSE OF ASSESSMENTS. The assessments levied by the Association shall be used exclusively for the purposes of promoting the health, safety, welfare and recreation of the residents in the Property, and in particular for the improvement, maintenance and preservation of the Property, the services and the facilities devoted to said purposes that are related to the use and enjoyment of both the Common Elements and the Units situated upon the Property. Such uses may include, but are not limited to, the cost to the Association of the following: all insurance, repair, replacement and maintenance of the Common Elements; fire, extended coverage, vandalism, malicious mischief and liability insurance for the Condominium Units; management costs, taxes, legal and accounting fees as may from time to time be authorized by the Association; construction of other facilities; maintenance of easements upon, constituting a part of, appurtenant to or for the benefit of the Property; mowing grass, caring for the grounds and landscaping; roofs and exterior surfaces of all Buildings; garbage pickup; pest control; street maintenance; outdoor lighting; security service for the Property; water and sewer service furnished to the Property by or through the Association; discharge of any liens on the Common Elements; and other charges required by this Condominium Declaration, or other charges that the Association is authorized to incur. In addition, the Association shall establish a reserve for repair, maintenance and other charges as specified herein.

5.3 DETERMINATION OF ASSESSMENTS. The assessments shall be determined by the Board of Directors based upon the cash requirements necessary to provide for the payment of all estimated expenses growing out of or connected with the maintenance and operation of the Common Elements. This determination may include, among other items, taxes, governmental assessments, landscaping and grounds care, Common Area lighting, repairs and renovation, garbage collections, wages, water charges, legal and accounting fees, management costs and fees, expenses and liabilities incurred by the Association under or by reason of this Declaration, expenses incurred in the operation and maintenance of recreation and administrative facilities, payment of any deficit remaining from a previous period and the creation of a reserve contingency fund. The

omission or failure of the Board to fix the assessment for any month shall not be deemed a waiver, modification or a release of the Owners from the obligation to pay.

5.4 INITIAL ASSESSMENT AND MAXIMUM MONTHLY ASSESSMENT.

a. The monthly assessments shall be made according to each Owner's proportionate or percentage interest in and to the Common Elements provided in Exhibit "C" attached hereto and shall commence upon conveyance of the Unit to the Owner.

b. At least thirty (30) days prior to January 1st, the Board of Directors shall determine the annual budget for the Association and shall set the monthly assessment for the next succeeding twelve (12)-month period. Said monthly assessment shall not exceed one hundred twenty percent (120%) of the monthly assessment allowed for January of the preceding year. At any time during the calendar year, the Board shall have a right to adjust the monthly assessments, as long as any such adjustment does not exceed the maximum permitted herein, with thirty (30) days' written notice given to each Owner. Written notice of the monthly assessment adjustment shall be sent to every Owner subject thereto. The due date shall be established by the Board, and unless otherwise provided or unless otherwise agreed by the Association, the Board shall collect the assessments monthly in accordance with Paragraph 5.1 hereof. If the Board determines at any time during the calendar year that a greater increase of the monthly assessment is required to adequately perform the duties and responsibilities of the Association and pay all expenses thereof, then the Board may call a special meeting of the Owners. By the assent of a two-thirds (2/3) vote of the quorum of Owners, present at such meeting, the monthly assessment may be set at whatever level such Owners approve. The new assessment shall become the basis for future annual increases, using the one hundred twenty percent (120%) formula, as above outlined.

c. In the event that the Board shall not approve an estimated annual budget or shall fail to determine new assessments for any year, or shall be delayed in doing so, each Unit Owner shall continue to pay each month the amount of his respective monthly assessment as last determined.

84046 4428

d. The Board of Directors shall have authority to lower the monthly assessment, if it deems feasible.

5.5 SPECIAL ASSESSMENTS FOR IMPROVEMENTS. In addition to the annual assessments authorized above, the Association, through the Board of Directors, may levy at any time during the calendar year a special assessment applicable to that year only, for the purpose of defraying, in whole or in part, Common Expenses not anticipated by the annual budget, contingency or reserve funds, including the cost of construction or reconstruction, repair or replacement of the Common Elements, as well as the necessary fixtures and personal property related thereto. Any such assessment must be approved by a two-thirds (2/3) vote of the quorum of Owners voting in person or by proxy at a meeting duly called for this purpose. The Declarant will be treated as all other Unit Owners for purposes of special assessments. Said special assessments shall be assessed against each Owner in proportion to his Unit's ownership interest in the Common Elements as set forth herein.

5.6 COMMENCEMENT OF ASSESSMENTS. The monthly assessments provided for herein shall be due on the first day of the month. The assessments shall be prorated if the ownership of a Unit commences on a day other than the first day of the month. On Units owned by the Declarant, the assessment shall commence on the first day of the month after the Declarant Control Period is terminated, in accordance with Paragraph 5.11 herein.

5.7 NO EXEMPTION. No Owner may exempt himself from liability for his contribution towards the Common Expenses by waiver of the use or enjoyment of any of the General or Limited Common Elements or by abandonment of his Unit.

5.8 LIEN FOR ASSESSMENTS.

a. All common monthly assessments and special assessments assessed but unpaid by a Unit Owner for its share of Common Expenses chargeable to its respective Condominium Unit, including interest thereon at ten percent (10%) per annum, shall constitute a lien on such Unit superior (prior) to all other liens and encumbrances, except only for:

(1) All taxes and special assessments levied by governmental and taxing authorities; and

(2) All liens securing sums due or to become due under any duly recorded mortgage, vendor's lien or deed of trust.

b. To evidence such lien the Association may, but shall not be required to, prepare written notice setting forth the amount of such unpaid indebtedness, the name of the Owner of the Condominium Unit and a description of the Condominium Unit. Such notice shall be signed by one (1) of the Board of Directors and may be recorded in the Office of the Clerk and Recorder of Dallas County, Texas. Such lien for the Common Expenses shall attach from the date of the failure of payment of the assessment. Such lien may be enforced by foreclosure of the defaulting Owner's Condominium Unit by the Association. Any such foreclosure sale is to be conducted in accordance with the provisions applicable to the exercise of powers of sale in mortgages and deeds of trust, as set forth in Section 51.002 of the Texas Property Code, as amended by Acts 1989, 68th Leg., Ch. 915 (Sec. 3810 Revised Civil Statutes), or in any manner permitted by law. Each Owner, by accepting a deed to his Unit, expressly grants to the Association a power of sale, as set forth in said Section 51.002, in connection with the assessment lien. In any such foreclosure, the Owner shall be required to pay the costs and expenses of such proceedings, the costs and expenses for filing the notice or claim of lien and all reasonable attorney's fees. The Owner shall also be required to pay to the Association a reasonable rental for the Condominium Unit during the period of foreclosure, that being the point in time after the foreclosure is posted, and the Association shall be entitled to a receiver to collect same. The Association shall have the power to bid in the Condominium Unit at foreclosure sale and to acquire and hold, lease, mortgage and convey same.

c. The amount of the Common Expenses assessed against each Condominium Unit shall also be a debt of the Owner thereof at the time the assessment is made. Suit to recover a money judgment for unpaid Common Expenses shall be maintainable without foreclosing or waiving the lien securing same.

d. In addition, to the extent permitted by law, Declarant reserves and assigns to the Association, without recourse, a vendor's lien against each Unit to secure payment of a common assessment or special assessment which is levied pursuant to the terms hereof. Said liens may be enforced by appropriate judicial

proceedings and the expenses incurred in connection therewith, including, but not limited to, interest, costs and reasonable attorney's fees, shall be chargeable to the Owner in default. Such lien shall be subordinated and inferior to those liens listed in Subparagraphs 5.8a(1) and (2).

e. Any encumbrancer holding a lien on a Condominium Unit may pay any unpaid Common Expense payable with respect to such Unit, and upon such payment, such encumbrancer shall have a lien on such Unit for the amount paid of the same rank as the lien of his encumbrance.

5.9 SUBORDINATION OF THE LIEN TO MORTGAGES. The lien of the assessments provided for herein shall be subordinate to the lien of any recorded mortgage or mortgages granted or created by the Owner of any Condominium Unit to secure the payment of monies advanced and used for the purpose of purchasing and/or improving such Unit. Sale or transfer of any Unit shall not affect the assessment lien; provided, however, that the sale or transfer of any Condominium Unit pursuant to a foreclosure, a deed in lieu of foreclosure, assignment in lieu of foreclosure under such purchase money or improvement mortgages or deeds of trust shall extinguish the lien of such assessments as to payments thereof coming due prior to such sale or transfer, except for claims for its pro-rata share of such assessments resulting from a reallocation among all Units, which reallocation, if necessary, will require a readjustment of the common assessment as provided in Paragraph 5.4b. No sale or transfer shall relieve such Condominium Unit, or the Owners thereof, from liability for any assessments thereafter becoming due or from the lien thereof.

5.10 STATEMENT OF ASSESSMENTS. Upon the written request of any Owner or any encumbrancer or prospective encumbrancer of a Condominium Unit, the Association, by its Board of Directors, shall issue a written statement setting forth the unpaid assessments, if any, with respect to the subject Unit, the amount of the current monthly assessments, the date of such assessment and the due date, credit for advance payments or for prepaid items, including, but not limited to, insurance premiums, which shall be conclusive upon the Association in favor of all persons who rely thereon in good faith. Unless such request for a statement of indebtedness shall be complied with within ten (10) days, all unpaid assessments which become due prior to the date of making of such request shall be subordinate to the lien of the person requesting such statement.

84046 4431

The Purchaser, Donee or other transferee of a Unit, by deed or other writing (herein called "Grantee"), shall be jointly and severally liable with the transferor of such Unit (herein called "Grantor") for all unpaid assessments against the latter for his proportionate share of the Common Expenses up to the time of the grant or conveyance, without prejudice to the Grantee's right to recover from Grantor the amounts paid by the Grantee, but such transferee shall be personally liable only if he expressly assumes such liability. The Grantee shall be entitled to a statement from the Board of Directors, setting forth the amount of the unpaid assessments, if any, with respect to the subject Unit, the amount of the current monthly assessment and the date such assessment becomes due, as well as any credit for advanced payments or for prepaid items, including, but not limited to, insurance premiums. This statement shall be conclusive upon the Association. Unless such request for a statement of indebtedness shall be complied with within ten (10) days of such request, such Grantee shall not be liable for, nor shall the Unit conveyed be subject to a lien for, any unpaid assessments against the subject Condominium Unit accruing prior to such ten (10)-day period.

5.11 OBLIGATION OF DECLARANT FOR ASSESSMENTS AND MAINTENANCE. During the Declarant Control Period, as provided in Paragraph 4.2 hereof, the Declarant shall be responsible for the difference between the cost of maintenance and assessments received from the other Unit Owners and shall not be limited to the regular monthly assessments for Units owned by Declarant until the end of the Declarant Control Period or until Declarant, at its option, chooses to make regular monthly payments, whichever first occurs. Should Declarant elect not to make regular monthly assessments, Declarant shall provide any additional funds necessary to pay actual cash outlays required to fund current operating expenses of the Association. After the Declarant Control Period is terminated or earlier at Declarant's option, Declarant shall pay the regular monthly assessment for each Unit or Units it owns. In no event shall Declarant's liability for assessments be less than required by the Act.

ARTICLE VI

DESTRUCTION OR OBSOLESCENCE OF IMPROVEMENTS

6.1 DESTRUCTION OR OBSOLESCENCE.

a. This Declaration hereby makes mandatory the irrevocable appointment of an Attorney In Fact to deal with the Property upon

84046 4432

its destruction, obsolescence or condemnation. Title to any Condominium Unit is declared and expressly made subject to the terms and conditions hereof, and acceptance by any Grantee of a deed from the Declarant or from any Owner shall constitute appointment of the Attorney In Fact herein provided. All of the Owners irrevocably constitute and appoint HOLLAND OAKS OWNERS ASSOCIATION, INC., or its successor non-profit corporation, if same be hereafter organized, their true and lawful Attorney in their name, place and stead, for the purpose of dealing with the Property upon its destruction, obsolescence or condemnation, as hereinafter provided. As Attorney In Fact, the Association, by its authorized officers shall have full and complete authorization, right and power to make, execute and deliver any contract, deed or any other instrument with respect to the interest of a Condominium Unit Owner which is necessary and appropriate to exercise the powers herein granted.

b. Repair and reconstruction of the improvement(s), as used in the succeeding subparagraphs, means restoring the improvement(s) to substantially the same condition in existence prior to the damage, with each Unit and Common Elements having the same vertical and horizontal boundaries as before. The proceeds of any insurance collected shall be made available to the Association for the purpose of repair, restoration or replacements, unless all of the Owners and all of the First Mortgagees agree not to rebuild in accordance with the provisions set forth hereinafter:

(1) In the event of damage or destruction due to fire or other disaster, the insurance proceeds, if sufficient to reconstruct the improvement(s), shall be applied by the Association, as Attorney In Fact, to such reconstruction, and the improvement(s) shall be promptly repaired and reconstructed.

(2) If the insurance proceeds are insufficient to repair and reconstruct the improvement(s), and if such damage is not more than sixty-six and two-thirds percent (66-2/3%) of all the Common Elements as determined by a majority of the Unit Owners, not including land, such damage or destruction shall be promptly repaired and

84046 4433

reconstructed by the Association, as Attorney In Fact, using the proceeds of insurance and the proceeds of an assessment to be made against all of the Owners and their Condominium Units. Such deficiency assessment shall be a special assessment made pro rata according to each Owner's proportionate interest in and to the Common Elements and shall be due and payable within thirty (30) days after written notice thereof. The Association shall have the authority to cause the repair or restoration of the improvements using all of the insurance proceeds for such purpose notwithstanding the failure of an Owner to pay the assessment. The assessment provided for herein shall be a debt of each Owner and a lien on his Condominium Unit and may be enforced and collected as is provided in Article V hereof. The lien provided for herein shall be subordinate to any recorded first mortgage lien, as provided in Paragraph 5.9 of this Declaration. Should the Association choose to foreclose said lien, as provided in Article V, the proceeds derived from the sale of such Condominium Unit shall be used and disbursed by the Association, as Attorney In Fact, in the following order:

(a) For payment of taxes and special assessment liens in favor of any governmental assessing entity;

(b) For payment of the balance of the lien of any duly recorded mortgage instrument;

(c) For payment of unpaid Common Expenses;

(d) For payment of junior liens and encumbrances in the order and extent of their priority; and

(e) The balance remaining, if any, shall be paid to the Condominium Unit Owner.

(3) If more than sixty-six and two-thirds percent (66-2/3%) of all of the Common Elements as determined by a majority of Unit Owners, not including land, are destroyed or damaged, and if the Owners representing the aggregate

ownership of one hundred percent (100%) of the Common Elements, do not voluntarily, within one hundred (100) days thereafter, make provision for reconstruction, the Association shall forthwith record a notice setting forth such fact or facts, and upon the recording of such notice by the Association's President and Secretary, the entire remaining Premises shall be sold by the Association, as Attorney In Fact for all of the Owners, free and clear of the provisions contained in this Declaration, the Plat and the By-Laws. The insurance settlement proceeds shall be collected by the Association, and such proceeds shall be divided by the Association according to each Unit Owner's interest (as such interests appear on the policy or policies), and such divided proceeds shall be paid into separate accounts, one such account for each Condominium Unit. Each such account shall be in the name of the Association, and shall be further identified by the number of the Unit and the name of the Owner. From each separate account, the Association, as Attorney In Fact, shall use and disburse the total amount (of each) of such accounts, without contribution from any one (1) account to another, toward the full payment of the lien of any first mortgage against the Condominium Unit represented by such separate account. There shall be added to each such account, the apportioned amount of the proceeds derived from the sale of the entire Property. Such apportionment shall be based upon each Condominium Unit Owner's proportionate interest in the Common Elements. The total funds of each account shall be used and disbursed, without contribution from one (1) account to another, by the Association, as Attorney In Fact, for the same purposes and in the same order as is provided in Subparagraphs b(2)(a) through (e) of Paragraph 6.1 hereof. Any decision to terminate the condominium status as herein provided must have the approval of First Mortgagees as provided in Paragraph 8.1c herein.

84046 4435

(4) If the Owners representing a total ownership interest of one hundred percent (100%) of the Common Elements adopt a plan for reconstruction, then all of the Owners shall be bound by the terms and provisions of such plan. Any assessment made in connection with such plan shall be a Common Expense and made pro rata according to each Owner's proportionate interest in the Common Elements and shall be due and payable as provided by the terms of the plan. The Association shall have the authority to cause the repair and restoration of the improvements using all of the insurance proceeds for such purpose notwithstanding the failure of an Owner to pay the assessment. The assessment provided for herein shall be a debt of each Owner and a lien on his Condominium Unit and may be enforced and collected as is provided in Paragraph 5.8 hereof, but will be subordinate to any duly recorded first mortgage lien, as provided in Paragraph 5.9 hereof. Should the Association foreclose said assessment lien, as provided in said Paragraph 5.8, the proceeds derived from sale of such Condominium Unit shall be used and disbursed by the Association, as Attorney In Fact, for the same purposes and in the same order as is provided in Subparagraphs b(2)(a) through (e) of Paragraph 6.1 hereof.

(5) The Owners representing an aggregate ownership interest of sixty-six and two-thirds percent (66-2/3%) of the Common Elements or more, may agree that the Common Elements of the Property are obsolete and that the same should be renewed or reconstructed. In such instance, the expenses thereof shall be payable by all of the Owners as Common Expenses.

(6) Any restoration, reconstruction or repair of the Project shall be performed substantially in accordance with this Declaration and the original Plans and specifications, unless other action is approved by the holders of mortgages on Units which have at least fifty-one percent (51%) of the votes of the Association.

84046 4436

(7) The Owners representing an aggregate ownership interest of one hundred percent (100%) of the Common Elements and all holders of first mortgages may agree that the Common Elements of the Property are obsolete and that the same should be sold. In such instance, the Association shall record a notice setting forth such fact or facts, and upon the recording of such notice by the Association's authorized officers, the entire Premises shall be sold by the Association, as Attorney In Fact, for all of the Owners, free and clear of the provisions contained in this Declaration, the Plat and the By-Laws. The sales proceeds shall be apportioned between the Owners and First Mortgagees as their interests may appear on the basis of each Owner's percentage or fraction of interest in the Common Elements, and such apportioned proceeds shall be paid into separate accounts, one such account for each Condominium Unit. Each such account shall be in the name of the Association, and shall be further identified by the number of the Unit and the name of the Owner. From each separate account, the Association, as Attorney In Fact, shall use and disburse the total amount of each of such funds, without contribution from (1) fund to another, for the same purposes and in the same order as is provided in Subparagraphs b(2)(a) through (e) of Paragraph 6.1 hereof.

6.2 JUDICIAL PARTITION. There shall be no judicial partition of the Common Elements, nor shall Declarant or any person acquiring any interest in the Project or any part thereof seek any such judicial partition, until the happening of the conditions set forth in Paragraph 6.1 hereof in the case of damage or destruction or unless the Property has been removed from the provisions of the Texas Condominium Act; provided, however, that if any Condominium Unit shall be owned by two (2) or more co-tenants, as tenants in common or as joint tenants, nothing herein contained shall be deemed to prevent a judicial partition between such co-tenants, but such partition shall not affect any other Condominium Unit.

6.3 CONDEMNATION.

a. If all or any part of the Property is taken or threatened to be taken by eminent domain or by power in the nature of eminent domain (whether permanent or temporary), the Association, as Attorney In Fact, and each Owner shall be entitled to participate in proceedings incident thereto at their respective expense. The Association shall give timely written notice of the existence of such proceedings to all Owners and to all First Mortgagees known to the Association to have an interest in any Condominium Unit. The expense of participation in such proceedings by the Association shall be borne by the Common Fund. The Association, as Attorney In Fact, is specifically authorized to obtain and pay for such assistance from attorneys, appraisers, architects, engineers, expert witnesses and other persons as the Association in its discretion deems necessary or advisable to aid or advise it in matters relating to such proceedings. All damages or awards for any such taking shall be deposited with the Association, as Attorney In Fact, and such damages or awards shall be applied as provided herein. In the event that an action in eminent domain is brought to condemn a portion of the Common Elements (together with or apart from any Condominium Unit), the Association, as Attorney In Fact, in addition to the general powers set out herein, shall have the sole authority to determine whether to defend or resist any such proceeding, to make any settlement with respect thereto, or to convey such Property to the condemning authority in lieu of such condemnation proceeding.

b. With respect to any such taking, all damages and awards shall be determined for the taking of the individual Units and for the taking of the Common Elements and for each Owner's interest therein. After the damages or awards for such taking are determined, such damages or awards shall be paid to the account of each Owner for the loss of the individual Unit plus an amount in proportion to his percentage or fractional ownership interest in the Common Elements to be applied or paid as set forth in Subparagraphs 6.1b(2)(a) through (e) hereof, unless restoration takes place as herein provided. The Association, if it deems advisable, may call a meeting of the Owners, at which meeting the Owners, by a majority

84046 4438

vote, shall decide whether to replace or restore, as far as possible, the Common Elements so taken or damaged. In the event it is determined that such Common Elements should be replaced or restored by obtaining other land or building additional structures, this Declaration and the Map attached hereto shall be duly amended by instrument executed by the Association, as Attorney In Fact, on behalf of the Owners. In the event that such eminent domain proceeding results in the taking of or damage to one (1) or more, but less than sixty-six and two-thirds percent (66-2/3%) of the total number of Condominium Units, then the damages and awards for such taking shall be determined for each Condominium Unit and the following shall apply:

(1) The Association shall determine which of the Condominium Units damaged by such taking may be made tenantable for the purposes set forth in this Declaration, taking into account the nature of this Condominium Project and the reduced size of each Condominium Unit so damaged.

(2) The Association shall determine whether it is reasonably practicable to operate the remaining Condominium Units of the Project, including those damaged Units which may be made tenantable, as a Condominium in the manner provided in this Declaration.

(3) In the event that the Association determines that it is not reasonably practicable to operate the undamaged Condominium Units and the damaged Units which can be made tenantable, then the Condominium Project shall be deemed to be regrouped and merged into a single estate owned jointly in undivided interest by all Owners, as tenants in common, in the proportionate ownership interest previously owned by each Owner in the Common Elements.

(4) In the event that the Association determines it will be reasonably practicable to operate the undamaged Condominium Units and the damaged Units which can be made tenantable as a Condominium Unit, then the damages and awards made with respect to each Unit which has been determined to be capable of being made tenantable shall be

applied to repair and to reconstruct such Condominium Unit so that it is made tenantable. The restoration shall be performed in accordance with this Declaration and the original Plans and specifications, unless other action is approved by holders of mortgages on the remaining Units which have at least fifty-one percent (51%) of the votes in the Association. If the cost of such work exceeds the amount of the award, the additional funds required shall be assessed against those Condominium Units which are tenantable. With respect to those Units which may not be tenantable, the award made shall be paid as set forth in Subparagraphs 6.1b(2)(a) through (e) hereof; and the remaining portion of such Units, if any, shall become part of the Common Elements. Upon the payment of such award for the account of such Owner as provided herein, such Condominium Unit shall no longer be a part of the Condominium Project, and the proportionate ownership interest in the Common Elements appurtenant to each remaining Condominium Unit which shall continue as part of the Condominium Project shall be equitably adjusted to distribute the ownership of the undivided interest in the Common Elements among the reduced number of Owners based upon the square footage of the individual remaining Units in proportion to the total square footage of all the remaining Units.

(5) If sixty-six and two-thirds percent (66-2/3%) or more of the Condominium Units are taken or damaged by such taking, all damages and awards shall be paid to the accounts of the Owners of Units, as provided herein; and this Condominium Regime shall terminate upon such payment. Such termination of condominium status shall require the approval of the Mortgagees as provided in Paragraph 8.1C herein. Upon such termination, the Condominium Units and Common Elements shall be deemed to be regrouped and merged into a single estate owned in undivided interest by all Owners as tenants in common in

34046 4440

the proportionate ownership interest previously owned by each Owner in the Common Elements. The Owners representing an aggregate ownership interest of sixty-seven percent (67%) of the Common Elements and holders of first mortgages on Units which have at least sixty-seven percent (67%) of the votes on Units subject to first mortgages may agree that the Property should be sold. In such instance, the Association shall record a notice setting forth such fact or facts, and upon the recording of such notice by the Association's authorized officers, the entire Premises shall be sold by the Association, as Attorney in Fact, for all of the Owners, free and clear of the provisions contained in the Declaration, the Plat and the By-Laws. The sales proceeds shall be apportioned between the Owners and First Mortgagees as their interests may appear on the basis of each Owner's proportionate ownership interest in the regrouped estate. Any damages, awards, or sales proceeds provided in this paragraph to be paid to or for the account of any Owner by the Association shall be applied as set forth in Subparagraphs 6.1b(2)(a) through (e) hereof.

ARTICLE VII

PROTECTION OF MORTGAGEE

7.1 NOTICE TO ASSOCIATION. An Owner who mortgages his Unit shall notify the Association, giving the name and address of his Mortgagee. Each Mortgagee shall be permitted to notify the Association of the fact that such Mortgagee holds a deed of trust or mortgage on a Condominium Unit. The Board shall maintain such information in a book entitled "Mortgagees of Condominium Units".

7.2 NOTICE OF DEFAULT; LAPSE IN INSURANCE. The Association shall notify a First Mortgagee in writing, upon written request of such Mortgagee identifying the name and address of the Mortgagee and the Unit number, of any default by the Mortgagor in the performance of such Mortgagor's obligations, as set forth in this Declaration, which is not cured within sixty (60) days. The Association, upon written request, shall notify a First Mortgagee of any

84040 4441

lapse, cancellation or material modification of any insurance policy or fidelity bond maintained by the Association.

7.3 EXAMINATION OF BOOKS. The Association shall permit First Mortgagees to examine the books and records of the Association upon request.

7.4 RESERVE FUND. The Association shall establish adequate reserve funds for replacement of Common Element components and fund the same by regular monthly payments rather than by extraordinary special assessments. In addition, there shall be established a working capital fund for the initial operation of the Condominium Project equal to at least two (2) months' estimated Common Assessments charge for each Unit, said deposit to be collected at closing of Unit sale.

7.5 ANNUAL AUDITS. Upon written request the Association shall furnish each First Mortgagee an annual audited financial statement of the Association within ninety (90) days following the end of each fiscal year of the Association.

7.6 NOTICE OF MEETINGS. The Association shall furnish each First Mortgagee upon request of such Mortgagee, prior written notice of all meetings of the Association and permit the designation of a representative of such Mortgagee to attend such meetings, one (1) such request to be deemed to be a request for prior written notice of all subsequent meetings of the Association.

7.7 NOTICE OF DAMAGE OR DESTRUCTION. The Association shall furnish the First Mortgagees timely written notice of any substantial damage or partial destruction of any Unit on which the First Mortgagee holds the mortgage if such loss exceeds One Thousand Dollars (\$1,000.00) and of any part of the Common Elements if such loss exceeds Ten Thousand Dollars (\$10,000.00).

7.8 MANAGEMENT AGREEMENTS. Any management agreement and/or service contract entered into by the Association will be terminable by the Association without cause and without payment of a termination fee upon ninety (90) days' written notice or with cause upon thirty (30) days' written notice, and the term of such management agreement will not exceed the period of three (3) years, renewable by agreement of the parties to such agreement for successive one (1)-year periods. In the event of the termination of the management agreement, as provided herein, the Association shall enter into a new management agreement with a new management agent prior to the effective date of the termination of old management agreement. Any decision to establish self-management by the Owners Association shall require the prior consent of

84046 4442

Owners of Units to which at least sixty-seven percent (67%) of the votes are allocated and the approval of first mortgage holders holding mortgages on Units which have at least fifty-one percent (51%) of the votes of the Association.

7.9 TAXES, ASSESSMENTS AND CHARGES. All taxes, assessments and charges which may become liens prior to the First Mortgage under local law shall relate only to the individual Condominium Units and not to the Condominium Project as a whole.

ARTICLE VIII

MISCELLANEOUS PROVISIONS

8.1 AMENDMENTS TO DECLARATION; APPROVAL OF OWNERS AND MORTGAGEES.

a. The consent of the Owners of Units to which at least sixty-seven percent (67%) of the votes in the Association are allocated and the approval of First Mortgagees holding mortgages on Units which have at least fifty-one percent (51%) of the votes of Units subject to mortgages shall be required to add or amend any provisions to this Declaration including those provisions which provide for, govern or regulate any of the following:

- (1) Voting;
- (2) Assessments, assessment liens or subordination of such liens;
- (3) Reserves for maintenance, repair and replacement of the Common Elements;
- (4) Insurance or fidelity bonds;
- (5) Rights to use of the Common Elements;
- (6) Responsibility for maintenance and repair of the Units and Common Elements;
- (7) Expansion of the Project;
- (8) Boundaries of any Unit, except as provided in Paragraph 2.10 herein;
- (9) Convertibility of Units into Common Elements, or Common Elements into Units;
- (10) Leasing of Units;

34046 4443

(11) Imposition of any right of first refusal or similar restriction on the right of a Unit Owner to sell, transfer, or otherwise convey his Unit;

(12) A decision by the owners' association to establish self management when professional management had been required previously by an eligible mortgage holder;

(13) Restoration or repair of the project (after a hazard damage or partial condemnation) in a manner other than that specified in the documents;

(14) Any action to terminate the legal status of the project after substantial destruction or condemnation occurs; or

(15) Any provisions which are for the express benefit of first mortgage holders, insurers, or guarantors of first mortgages.

b. The consent of Owners of Units to which at least sixty-seven percent (67%) of the votes in the Association are allocated and the approval of First Mortgagees holding mortgages on Units which have at least sixty-seven percent (67%) of the votes of Units subject to Mortgages, shall be required to:

(1) partition or subdivide any Unit. In addition to the approval of the Owner any mortgage holder, if any, must be obtained;

(2) by act or omission, seek to abandon, partition, subdivide, encumber, or transfer the Common Elements, other than the granting of easements for public utilities or other public, uses except where a greater percentage is required, as provided in Paragraph 3.2 hereof, or by the Act; or

(3) use hazard insurance proceeds for losses to any condominium property for other than the repair, replacement or reconstruction of such property, except as provided by statute in the case of substantial loss, and as provided in Paragraph 6.1b(3).

c. The consent of Owners of Units to which at least one hundred percent (100%) of the votes of the Association are allocated

84046 4444

and the approval of First Mortgagees holding mortgages on Units which have at least sixty-seven percent (67%) of the votes of Units subject to mortgages shall be required to terminate or abandon the condominium status of the Project by act or omission, except where a different percentage is mandated by the Act in the event of a termination due to destruction or condemnation.

d. Any amendment which would change the percentage or fraction of interest of the Unit Owners in the Common Elements, will require the consent of Owners of sixty-seven percent (67%) of the votes allocated in the Association and the approval of First Mortgagees holding mortgages on Units which have at least fifty-one percent (51%) of the votes of Units subject to mortgages, provided that the change of percentage or fraction of ownership must have the approval of each Unit Owner affected by said amendment.

e. Any amendment to the Declaration must be approved by the requisite percentages of ownership interest at a meeting called by the Association, so long as such meeting is required by law. Should the meeting requirement not be mandated by law, an amendment may be effected with the certification by the Secretary of the Association that the necessary Owner approval was obtained, or by obtaining the signatures of the Owners who hold the requisite percentage ownerships.

f. No amendment to the Declaration may alter or destroy a Unit or a Limited Common Element without the consent of the Owners affected and the Owners' First Mortgagees.

g. Any First Mortgagee who receives a written request to approve additions or amendments to the Declaration or By-Laws, and who does not deliver or post to the requesting party a negative response within thirty (30) days, shall be deemed to have approved such request. The Association shall give timely written notice to all First Mortgagees of any proposed action which would require the consent of a specified percentage of First Mortgagees.

h. Unless otherwise provided in this Paragraph 8.1 or elsewhere in this Declaration, any of the provisions herein may be amended by the consent of Owners of Units to which at least sixty-seven percent (67%) of the votes in the Association are allocated, provided that:

84046 4445

(i) No amendment shall affect the rights given to the Declarant, herein, without the consent of the Declarant;

(ii) No action to challenge the validity of an amendment adopted by the Association under this section or Paragraph 8.2 may be brought more than one (1) year after the amendment is recorded; and

(iii) To be effective, each amendment to the Declaration must be in writing, signed and acknowledged by the Board, indicating the required approval of such Owners and/or Mortgagees, or by the Declarant in the case of an amendment pursuant to Paragraph 8.2. Any such instrument shall be duly recorded in the Condominium Records of Dallas, Texas.

8.2 CORRECTION OF ERROR. Declarant reserves, and shall have the continuing right, until the end of the Construction Period, without the consent of the other Owners or any Mortgagee to amend this Declaration or the By-Laws for the purpose of resolving or clarifying any ambiguities or conflicts herein, or correcting any inadvertent misstatements, errors or omissions herein, or to comply with the requirements of Federal Home Loan Mortgage Corporation, Federal National Mortgage Association, Veterans Administration or Federal Housing Administration, as allowed by law.

8.3 OWNERSHIP OF COMMON PERSONAL PROPERTY. Upon termination of the Construction Period, as defined herein, Declarant shall execute and deliver a bill of sale to the Association transferring all items of personal property located on the Premises, furnished by Declarant, and intended for the common use and enjoyment of the Condominium Unit Owners and occupants. No Owner shall have any other interest and right thereto, and all such right and interest shall absolutely terminate upon the Owner's termination of possession of his Condominium Unit.

8.4 CHANGE IN DOCUMENTS. Upon written request, the holder of any mortgage covering any of the Condominium Units shall be entitled to written notification from the Association thirty (30) days prior to the effective date of any change in the Condominium documents.

8.5 NOTICE. All notices, demands or other notices intended to be served upon an Owner shall be sent by ordinary or certified mail, postage prepaid,

84046 4446

addressed in the name of such Owner in care of the Unit number and Building address of such Owner. All notices, demands or other notices intended to be served upon the Board of Directors of the Association or the Association, shall be sent by ordinary or certified mail, postage prepaid, to 3918 Holland Avenue, Dallas, Texas, 75219, until such address is changed by a notice of address change duly recorded in the Dallas County Condominium Records.

8.6 CONFLICT BETWEEN DECLARATION AND BY-LAWS. Whenever the application of the provisions of this Declaration conflict with the application of any provision of the By-Laws adopted by the Association, the provisions or application of this Declaration shall prevail.

8.7 INVALIDATION OF PARTS. If any of the provisions of this Declaration or any paragraph, sentence, clause, phrase or word or the application thereof in any circumstance be invalidated, such invalidity shall not affect the validity of the remainder of this Declaration and the application of any provision, paragraph, sentence, clause, phrase or word in any other circumstance shall not be affected thereby.

8.8 OMISSIONS. In the event of the omission from this Declaration of any word, sentence, clause, provision or stipulation which shall be necessary for the accomplishment of the intent and purposes hereof, or any part hereof, then such omitted matter shall be supplied by inference and/or by reference to the Act.

8.9 TEXAS CONDOMINIUM ACT. The provisions of this Declaration shall be in addition and supplemental to the Condominium Act of the State of Texas and to all other provisions of law.

8.10 GENDER. That whenever used herein, unless the context shall otherwise provide, the singular number shall include the plural, the plural the singular, and the use of any gender shall include all genders.

IN WITNESS WHEREOF, the Declarant has caused this instrument to be signed, sealed and delivered by its proper corporate officers and its corporate seal to be affixed, this 28th day of Feb, A.D., 1984.

3M3 PROPERTIES, INC.

By: Coleman McDuffee
Coleman McDuffee, President

ATTEST:

R. Miller
Secretary

THE STATE OF TEXAS §

COUNTY OF DALLAS §

BEFORE ME, the undersigned, a Notary Public in and for said County and State, on this day personally appeared Coleman McDuffee, President of 3M3 Properties, Inc., known to me to be the person and officer whose name is subscribed to the foregoing instrument and acknowledged to me that the same was the act of such corporation for the purposes and consideration therein expressed, and in the capacity therein stated.

GIVEN UNDER MY HAND AND SEAL OF OFFICE this the 28th day of February, A.D., 1984.

Wilma R. Harkins
Notary Public in and for
The State of Texas
My Commission Expires: 11-30-86

84046 4448

6777 97078

EXHIBIT "A"

LEGAL DESCRIPTION

BEING all of Lots 4 and 5 in City of Dallas Block 4/1566, Dallas County, Texas, and being more particularly described as follows:

COMMENCING at the intersection of the southeast right-of-way line of Throckmorton Street and the northeast right-of-way line of Holland Avenue, thence South 45° 00' 00" East along the southeast right-of-way of Holland a distance of 150.00 feet to the point of beginning;

THENCE departing the northeast right of way line of Holland Avenue North 45° 00' 00" East a distance of 160.00 feet to a corner;

THENCE South 45° 00' 00" East a distance of 100.00 feet to a corner;

THENCE South 45° 00' 00" West a distance of 160.00 feet to a corner in the northeast right of way line of Holland Avenue;

THENCE along the northeast right of way line of Holland Avenue North 45° 00' 00" West a distance of 100.00 feet to the point of beginning of this tract and containing 0.367 acres of land.

I, Billy L. Stephenson, a Registered Public Surveyor, do hereby certify to *3 M3 PROPERTIES* and *THE MORTGAGOR* that the plats attached hereto accurately represent the property as determined by an on the ground survey made under my direction and supervision subsequent to the completion of the improvements on the 19th day of October, 1983.

The legal description and the map marked Exhibit A substantially depict the locations of the building, the units, the unit numbers, the dimensions of the units, and the building description by letter. The lines and dimensions of said property are as indicated on the plat; the improvements lie wholly within the property lines and established setback lines except as shown.

There were no encroachments, conflicts, or protrusions visible on the date of the survey except as shown.

The property has access to a public road.

The surveyor has no knowledge of other visible easements, rights of way, or other easements of record affecting the property other than those shown.

This survey was performed in connection with the above transaction. Use of this survey for any other purpose or by other parties shall be at their risk and undersigned is not responsible to others for any loss resulting therefrom.

pict the locations of the building, the units, the unit numbers, the dimensions of the units, and the building description by letter. The lines and dimensions of said property are as indicated on the plat; the improvements lie wholly within the property lines and established setback lines except as shown.

There were no encroachments, conflicts, or protrusions visible on the date of the survey except as shown.

The property has access to a public road.

The surveyor has no knowledge of other visible easements, rights of way, or other easements of record affecting the property other than those shown.

This survey was performed in connection with the above transaction. Use of this survey for any other purpose or by other parties shall be at their risk and undersigned is not responsible to others for any loss resulting therefrom.

Billy L. Stephenson

Billy L. Stephenson
Registered Public Surveyor 1317

Unofficial Copy



BILLY L.
AND
CONSU
222
(2
DALLA

84046 4450

ck

y.

ss

Official Copy



**BILLY L. STEPHENSON
AND ASSOCIATES
CONSULTING ENGINEERS**
2320 HIGHLAND ROAD
(214)324-2461
DALLAS, TEXAS 75226

LEGAL DESCRIPTION

**HOLLAND OAKS
CONDOMINIUMS**
84046 4451

SHEET NO. 1 OF 3
SCALE: NONE
DRAWN BY: TNM
SURVEYED: 10-19-8
SURVEYED BY: DRM
CHECKED BY: BLS
JOB NO. 83022

3
83
M

Legal Copy

THROCKMORTON ST.

511

8' CONCRETE ALLEY SLAB

S 45° 00' 00" E 100.0'

POWER POLE

ASPHALT PAVEMENT

POWER POLE

COVERED PARKING

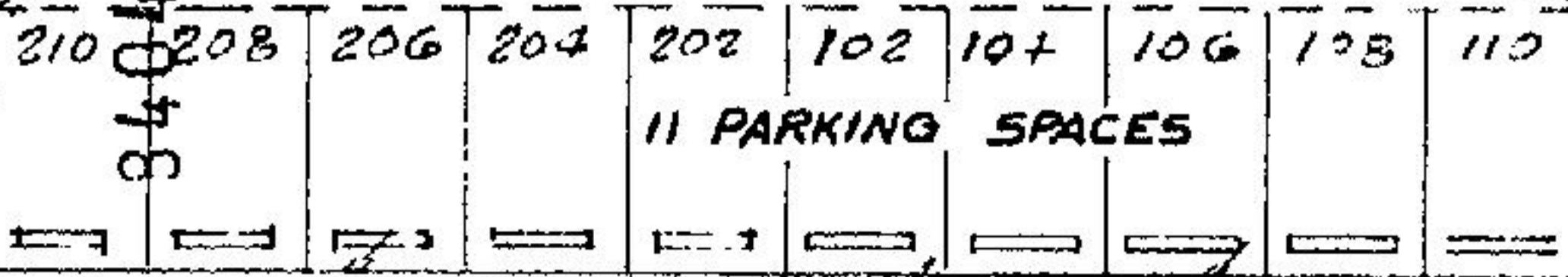

160.0'

160.0'

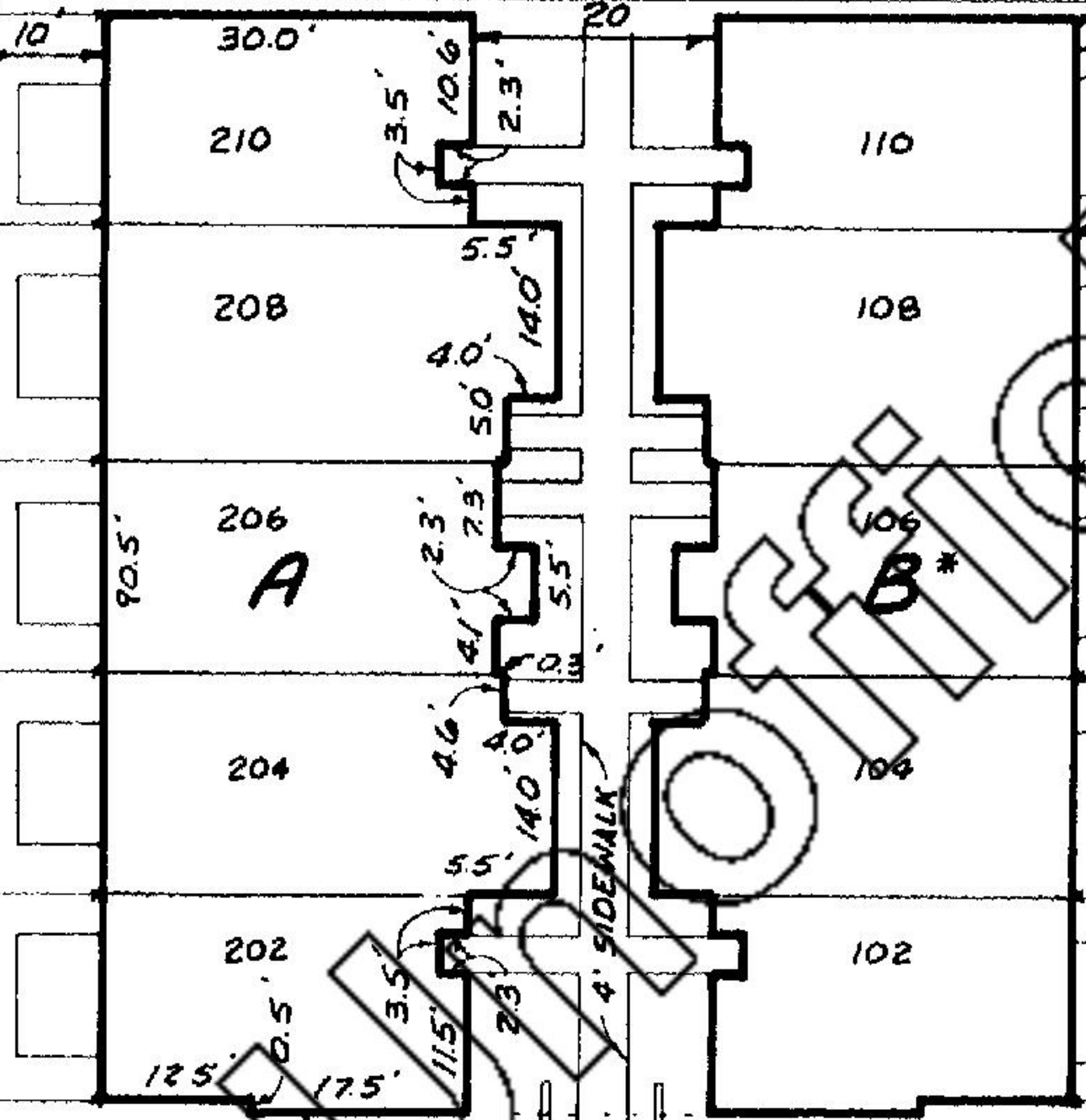

WOOD FENCE

PATIOS

* DIMENSIONS FOR BUILDING B ARE SAME AS FOR BUILDING A.

N 45° 00' 00" E

S 45° 00' 00" W

11 PARKING SPACES

CONCRETE WALL

ASPHALT PAVEMENT

Official Copy

84046 4453

c.i.p.

c.i.p.

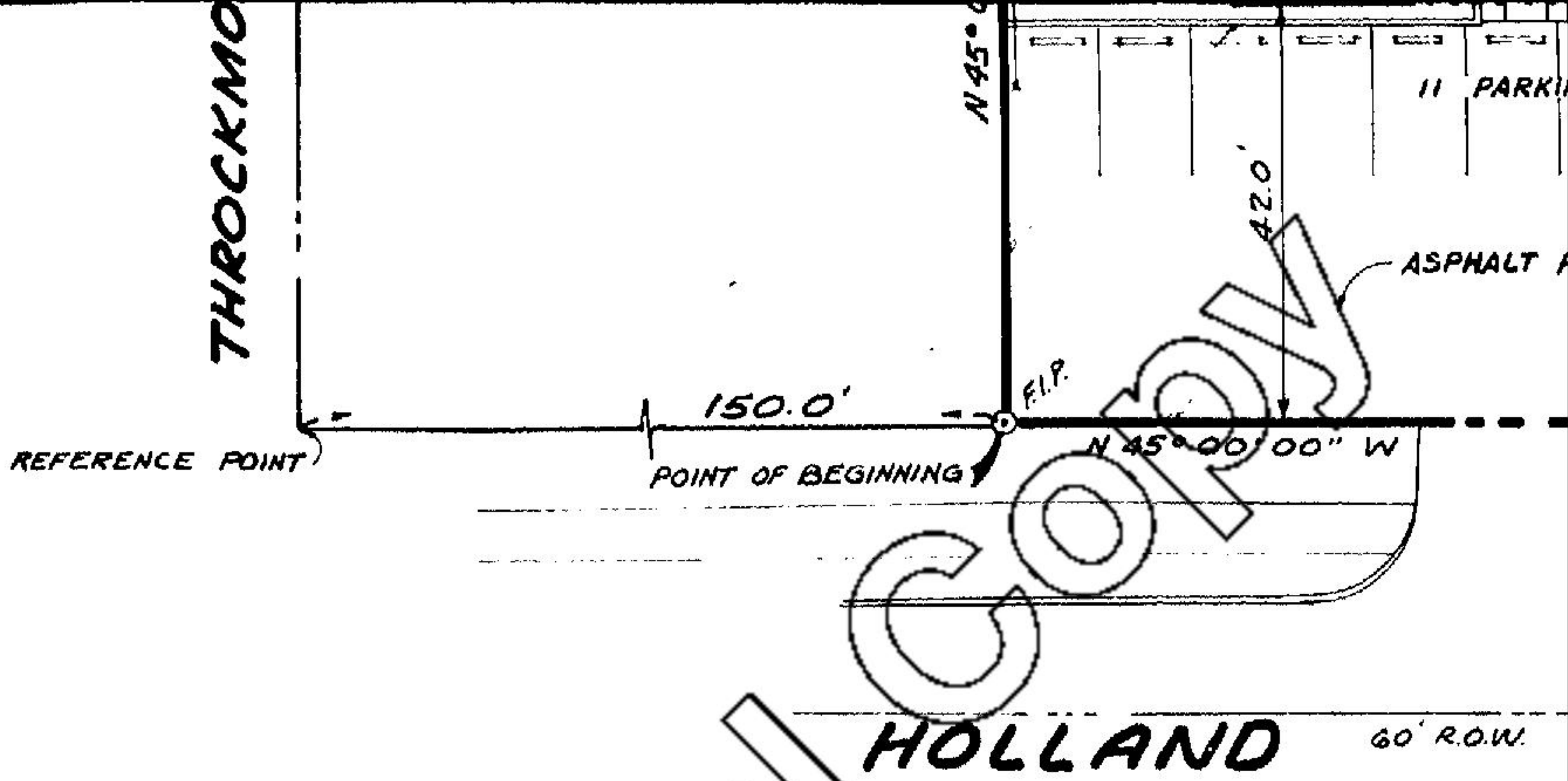

Unofficial Copy

04046 4454

N 45° 00' 00"

11 PARKING SPACES

42.0'

ASPHALT PAVEMENT

CONCRETE WALL

F.I.P.

F.I.P.

N 45° 00' 00" W

100.0'

17.5'

DOLLAND

60' R.O.W.

AVENUE

30' B-B

Unofficial Copy



GRAPHIC SCALE

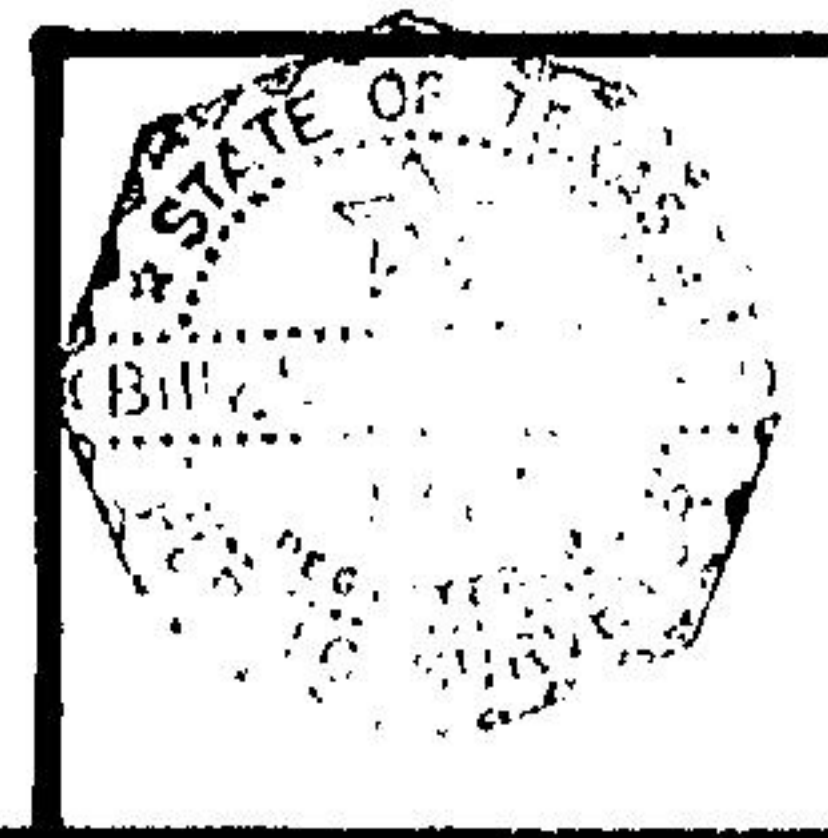

BILLY
AN
CON
DA

84046 1155

Official Copy

EXHIBIT "B"

**BILLY L. STEPHENSON
AND ASSOCIATES
CONSULTING ENGINEERS**
2220 HIGHLAND ROAD
(214)324-2461
DALLAS, TEXAS 75228

SITE PLAN

**HOLLAND OAKS
CONDOMINIUMS**

SHEET NO. 2 OF 3

SCALE: 1" = 20'

DRAWN BY: D.R.M.

SURVEYED 10-19-8

SURVEYED BY D.R.M.

CHECKED BY: B.L.S.

JOB NO. 88022

84046 1/4 56

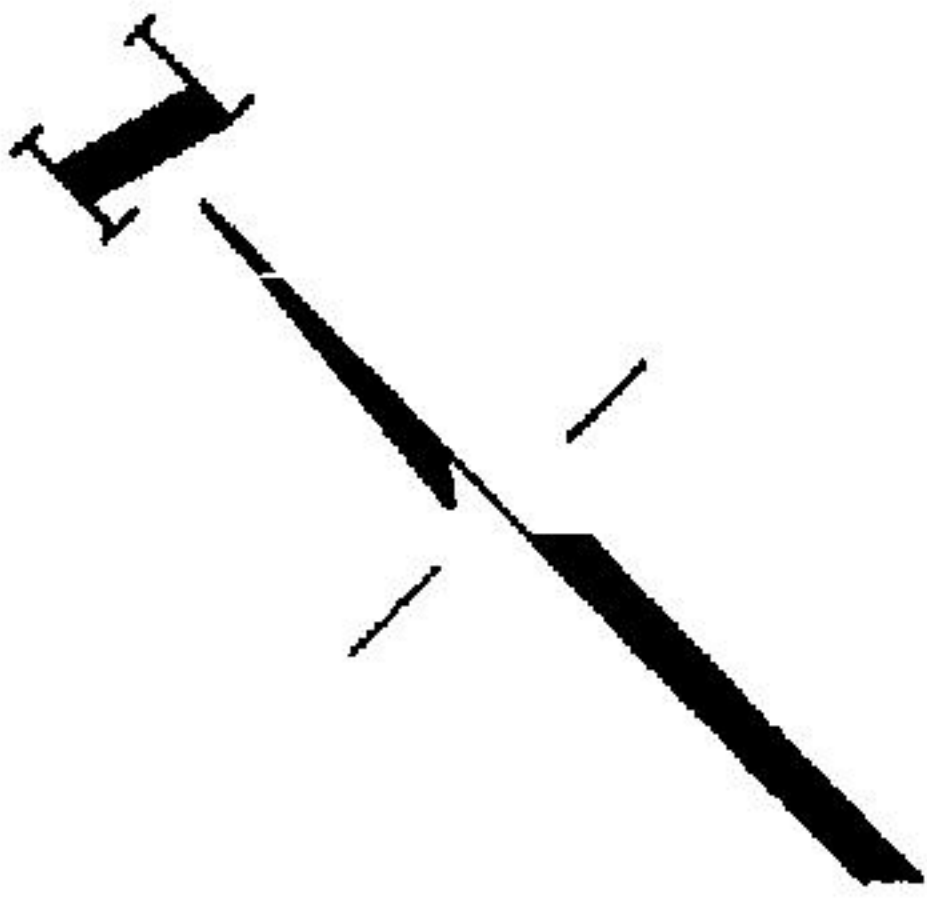

84046 4457

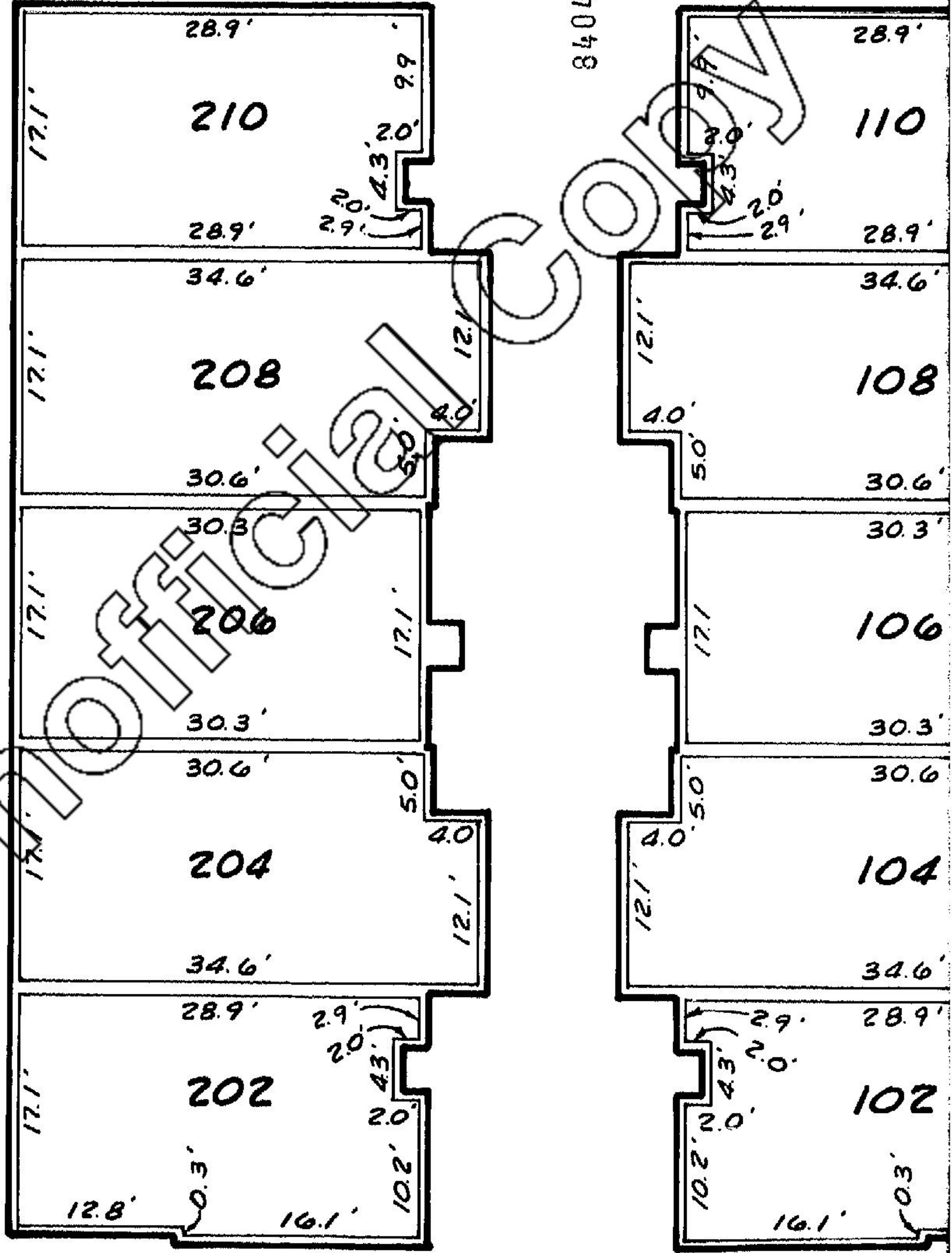

84046 4457

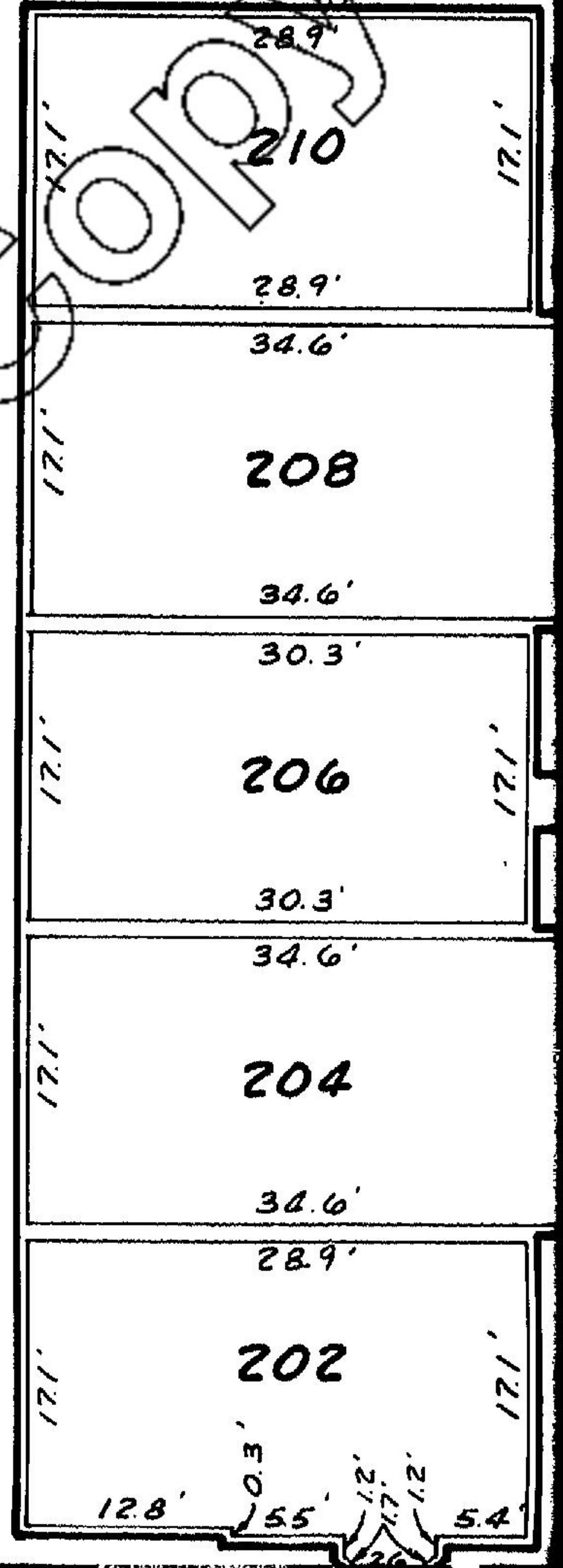
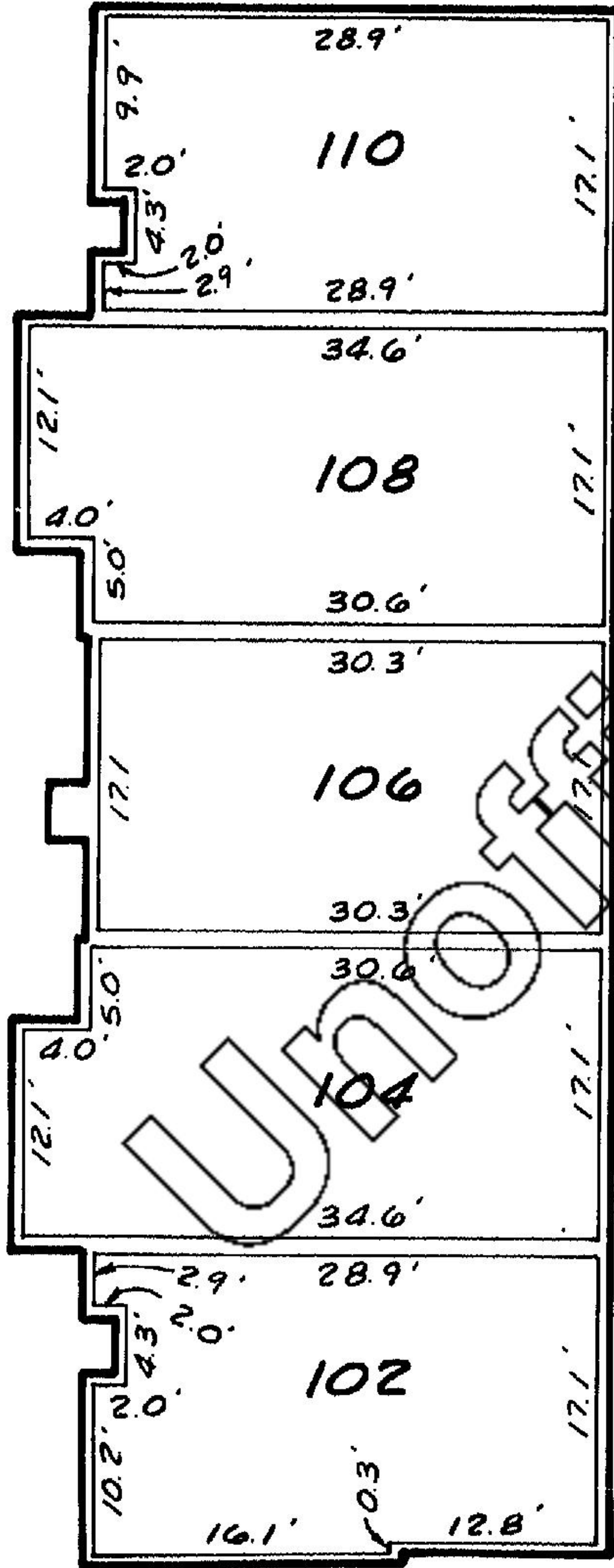

84046 4458

Official Copy

8577 4458
94048

8577 4458
94048

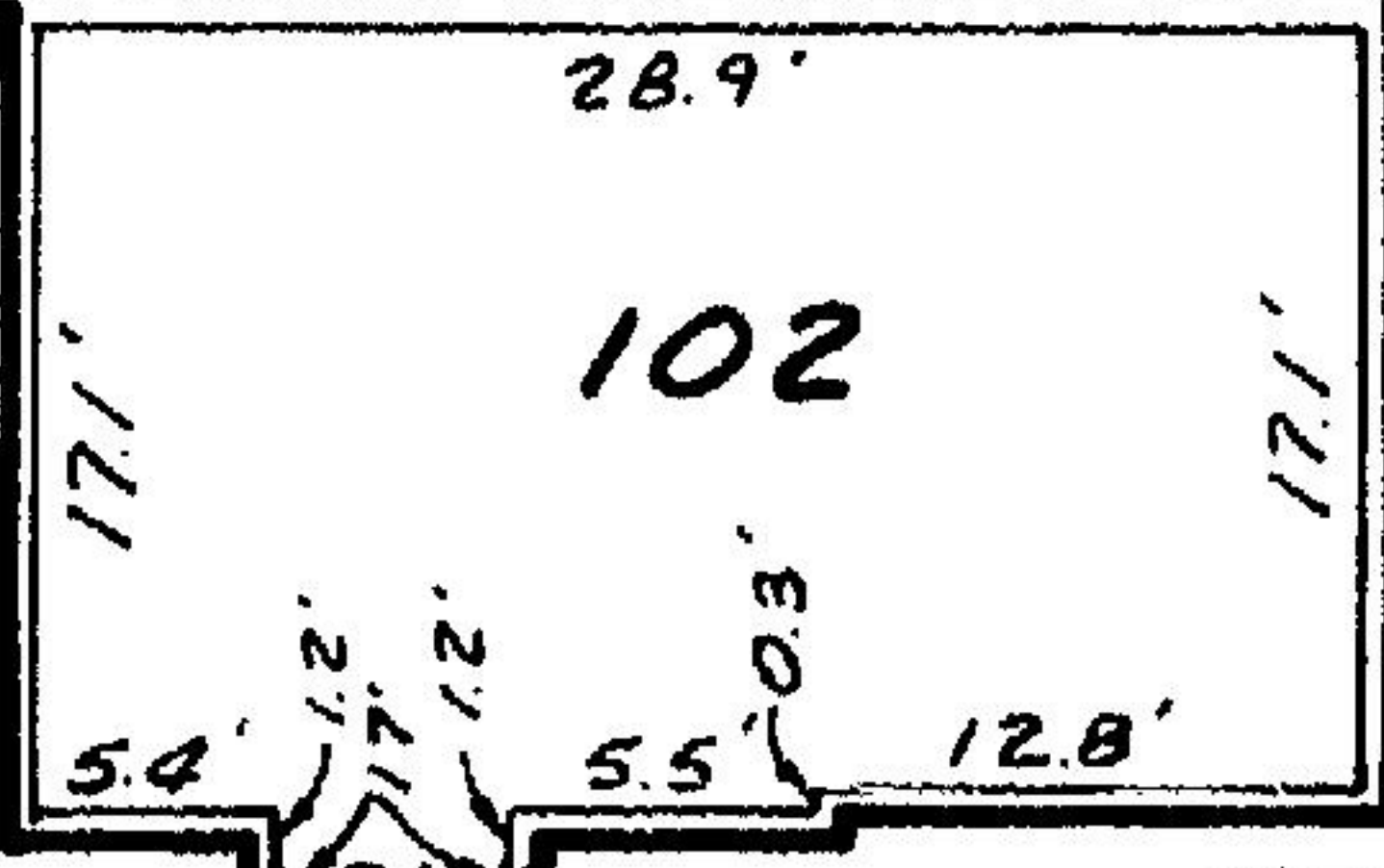
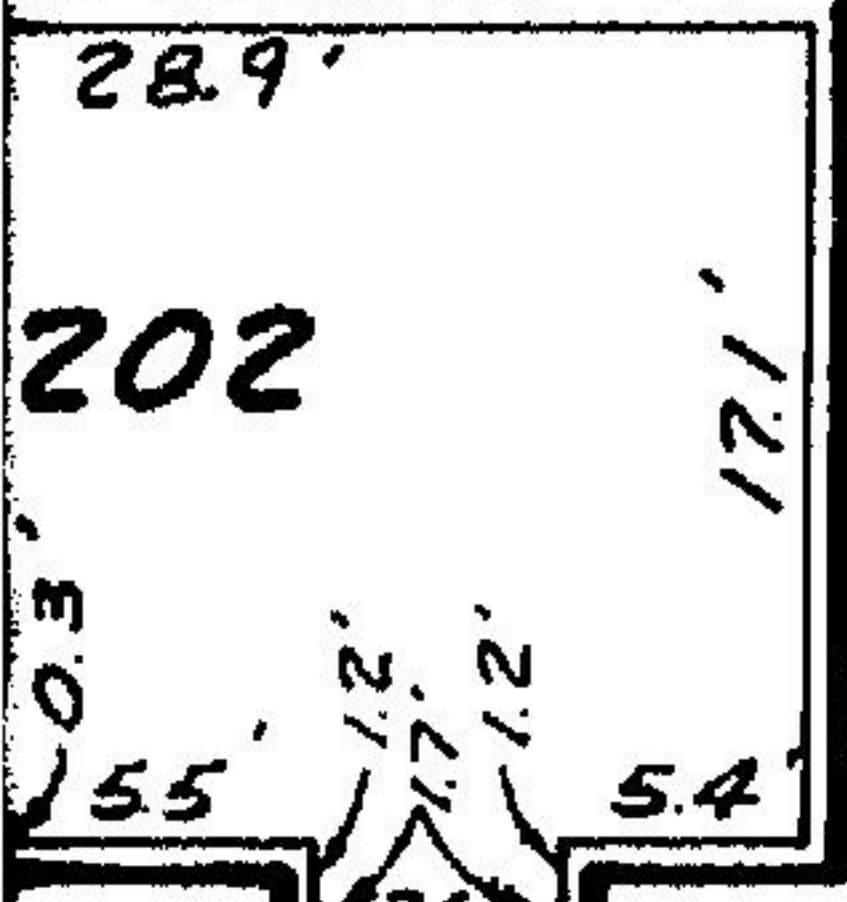
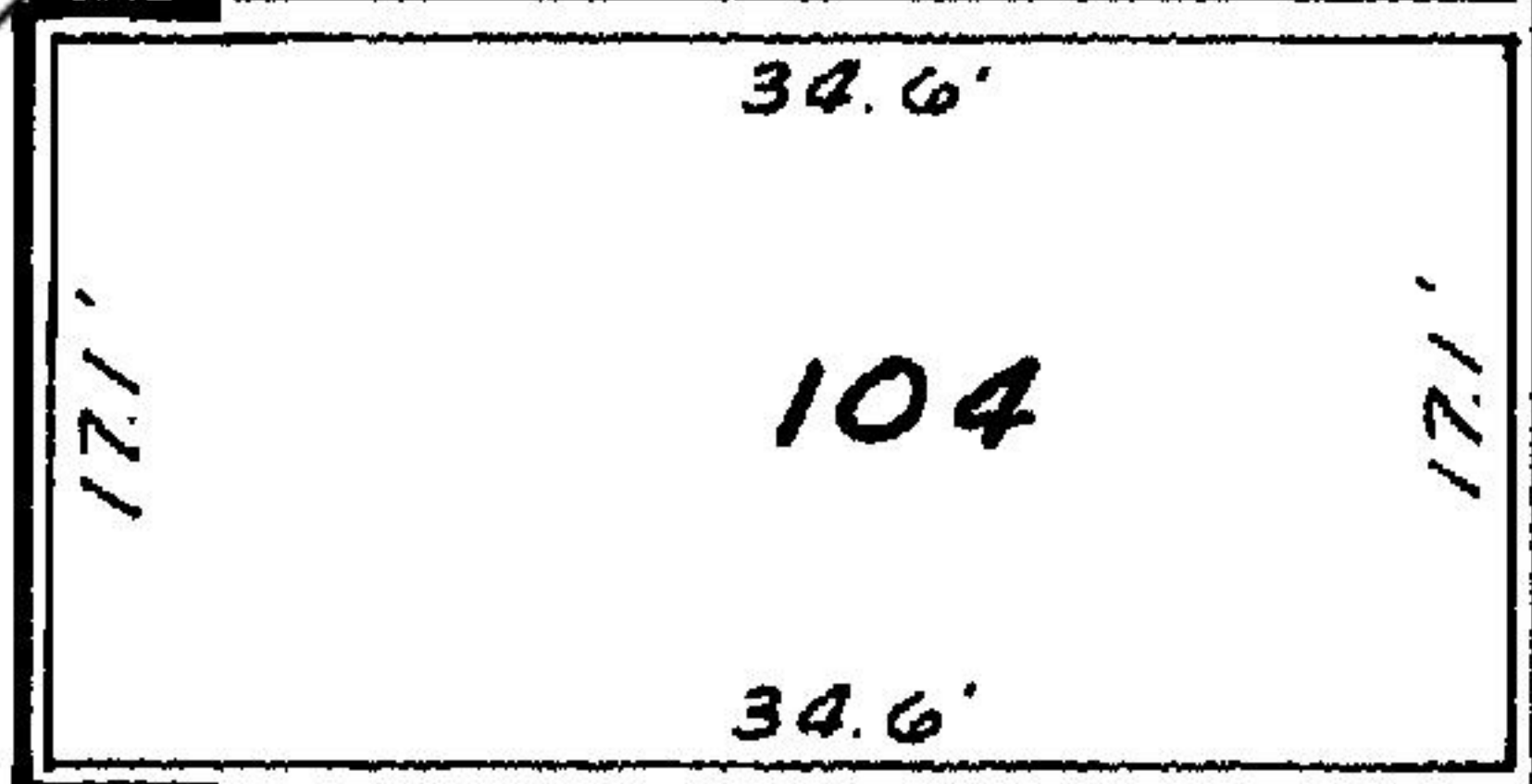
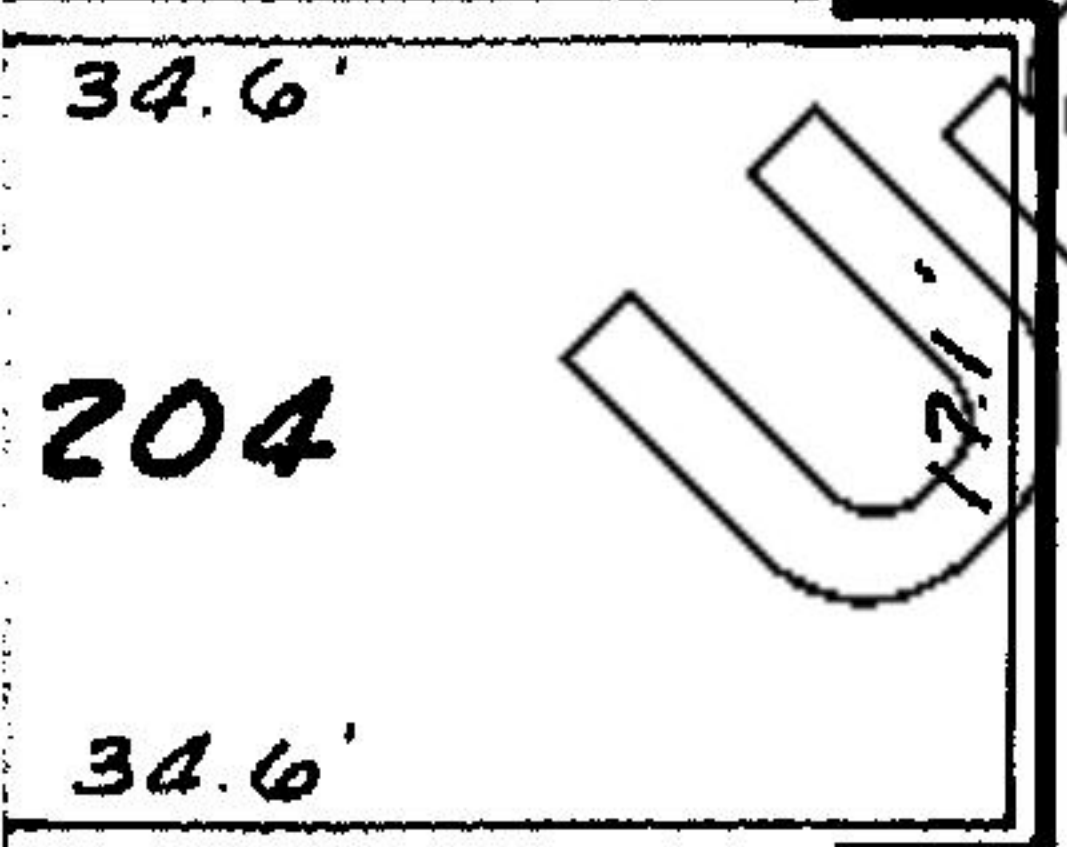
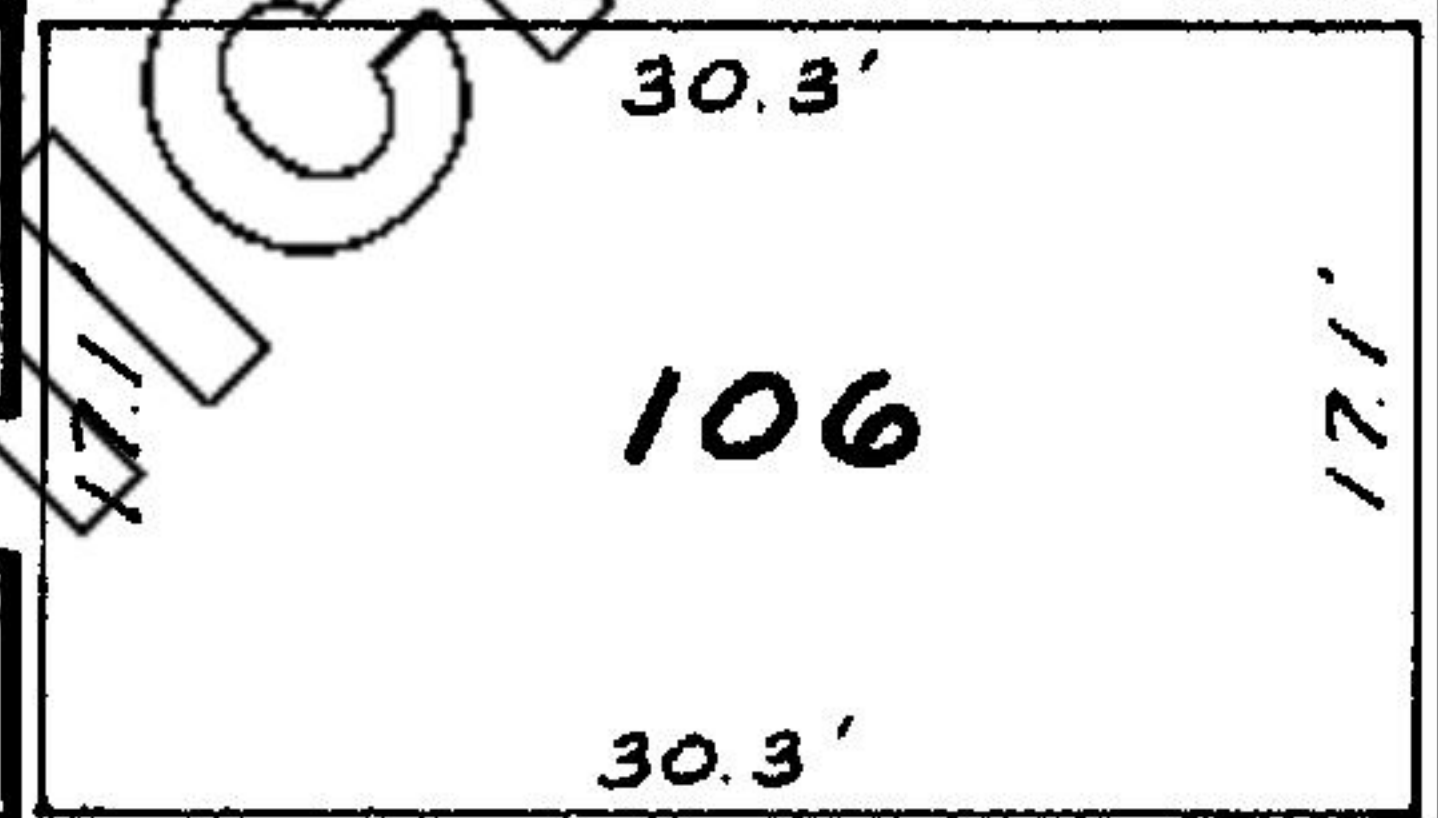
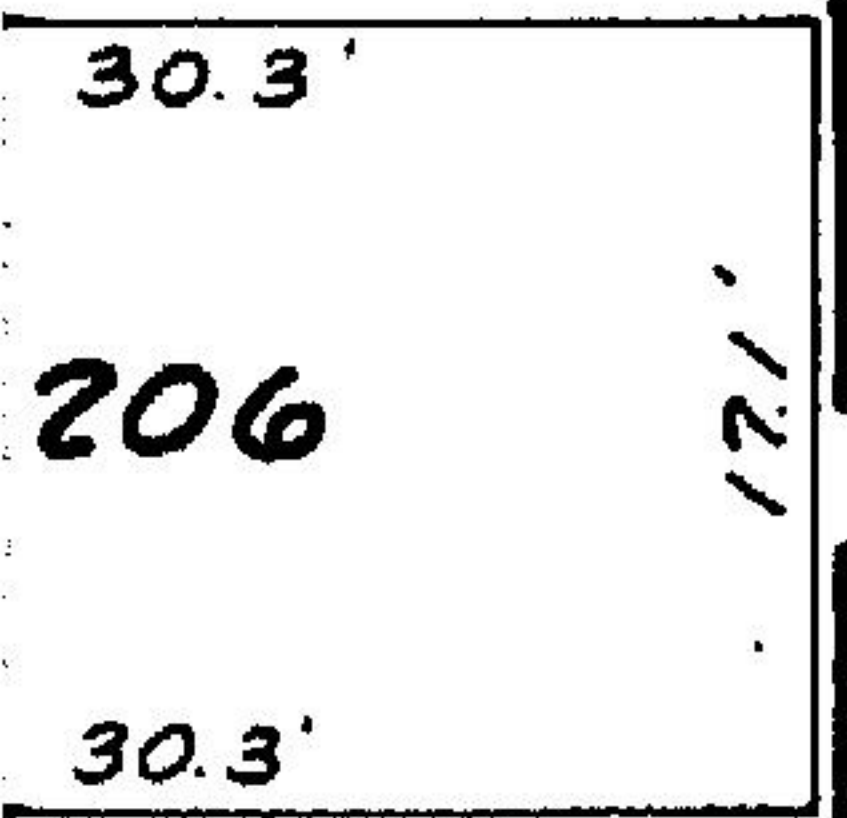
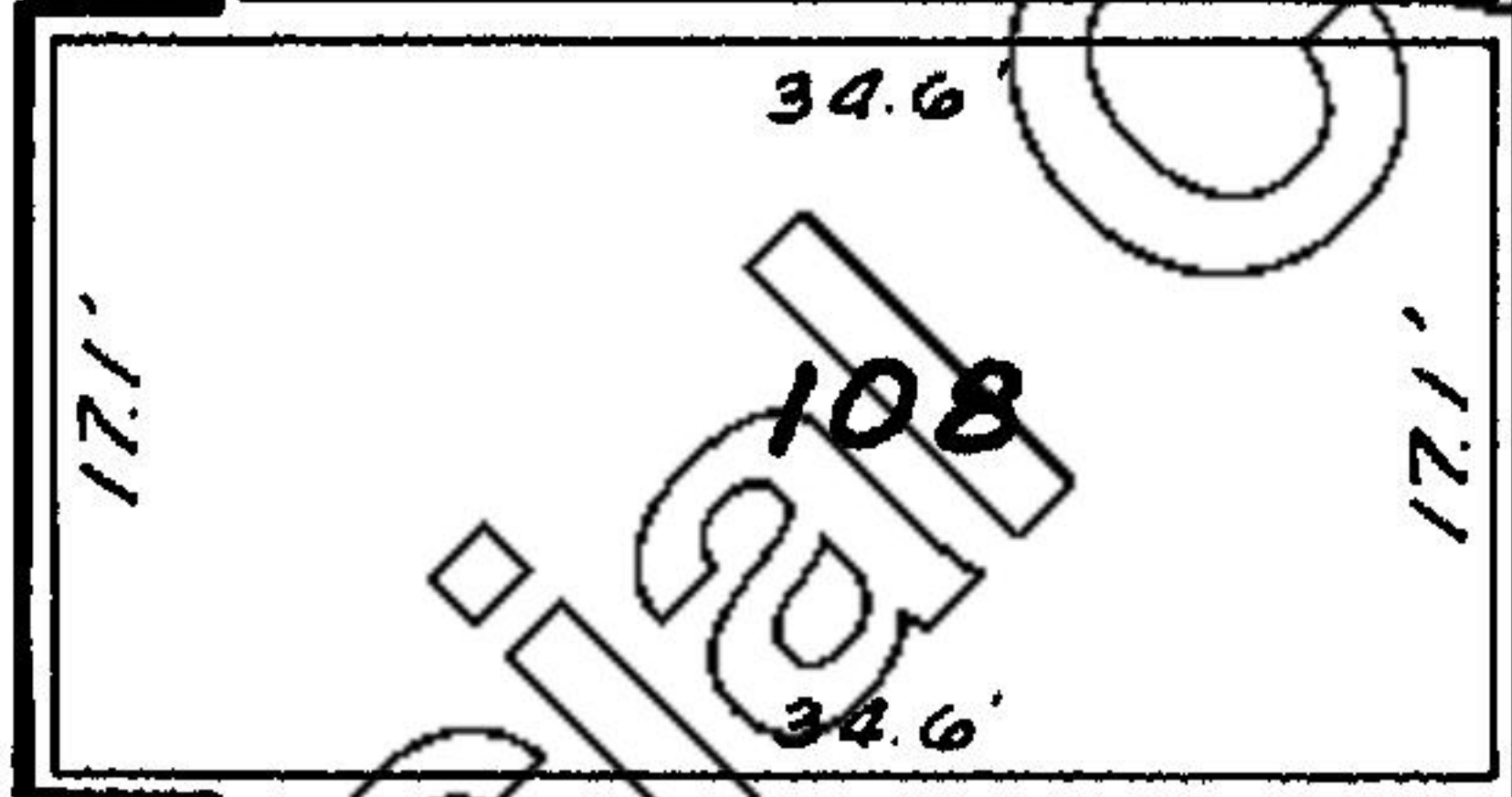
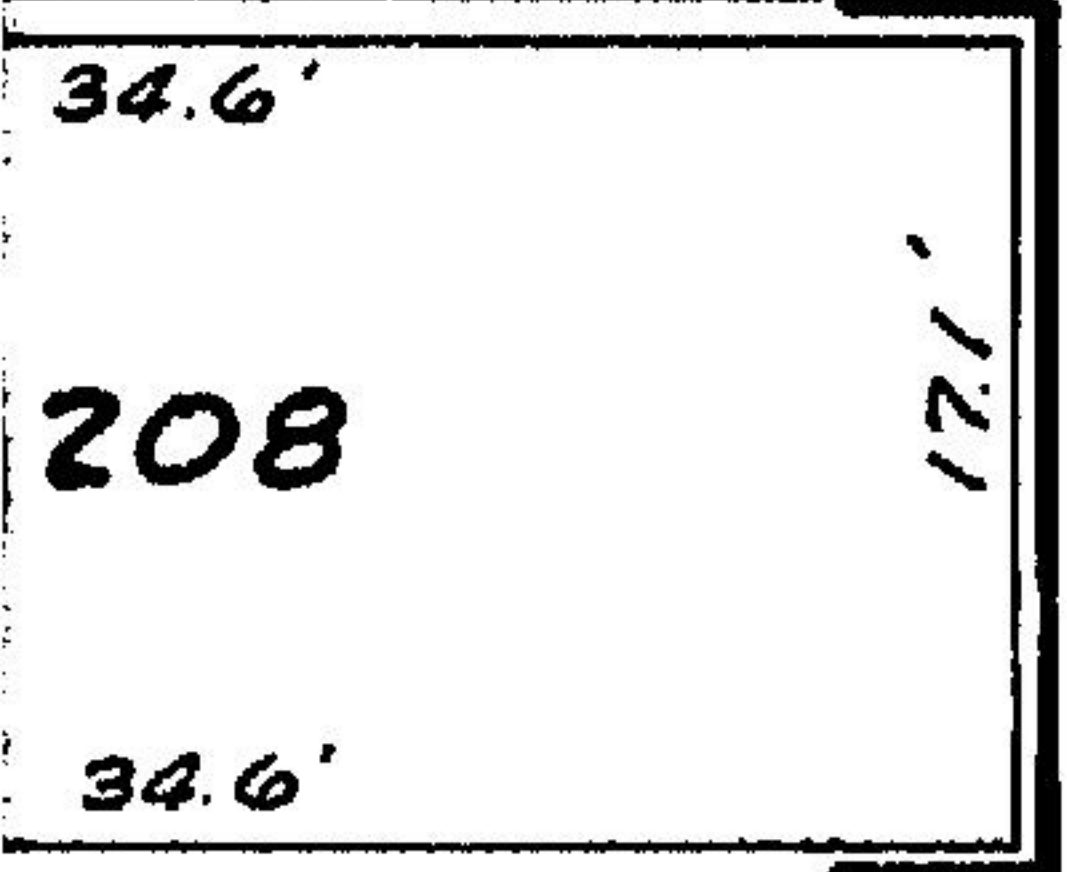
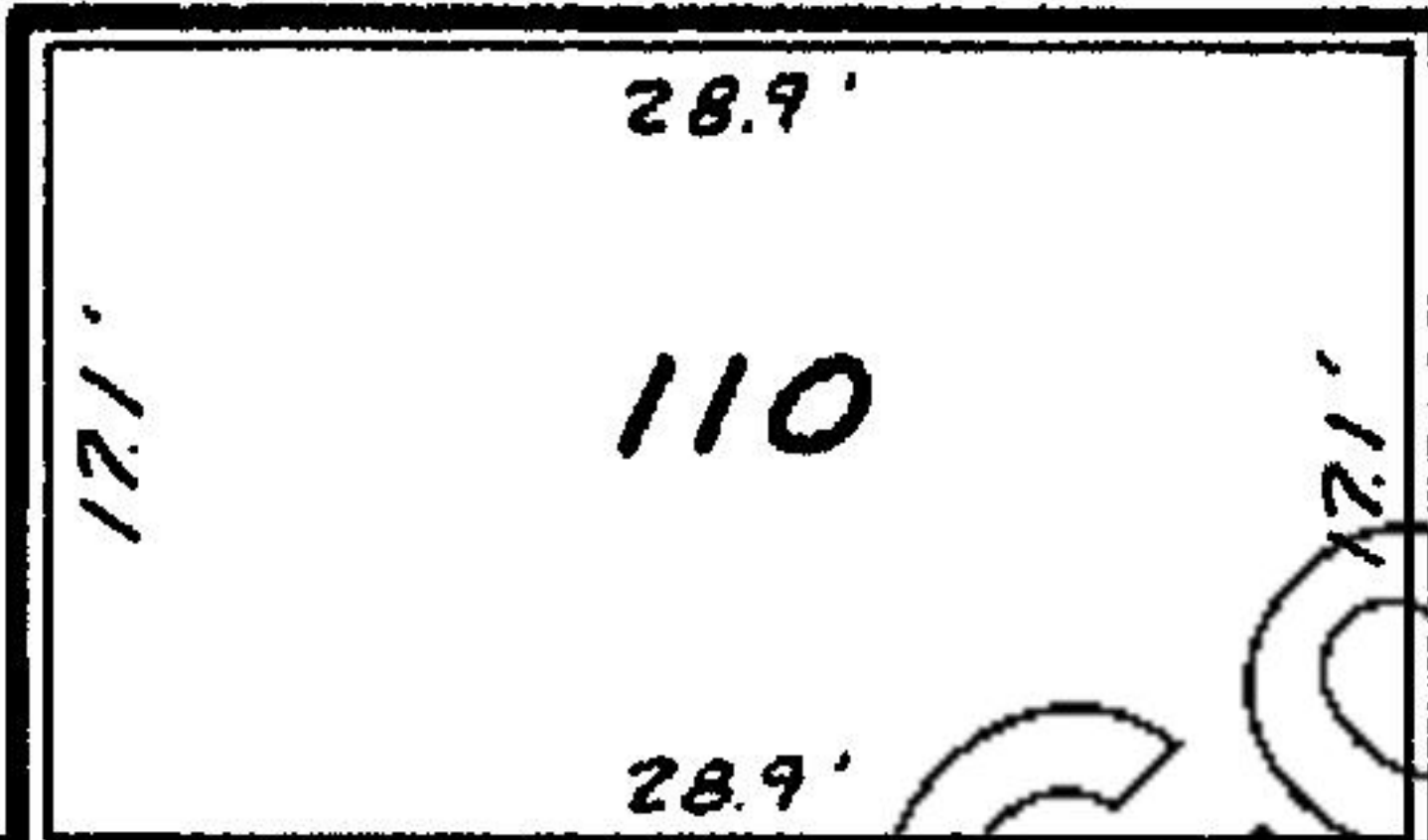
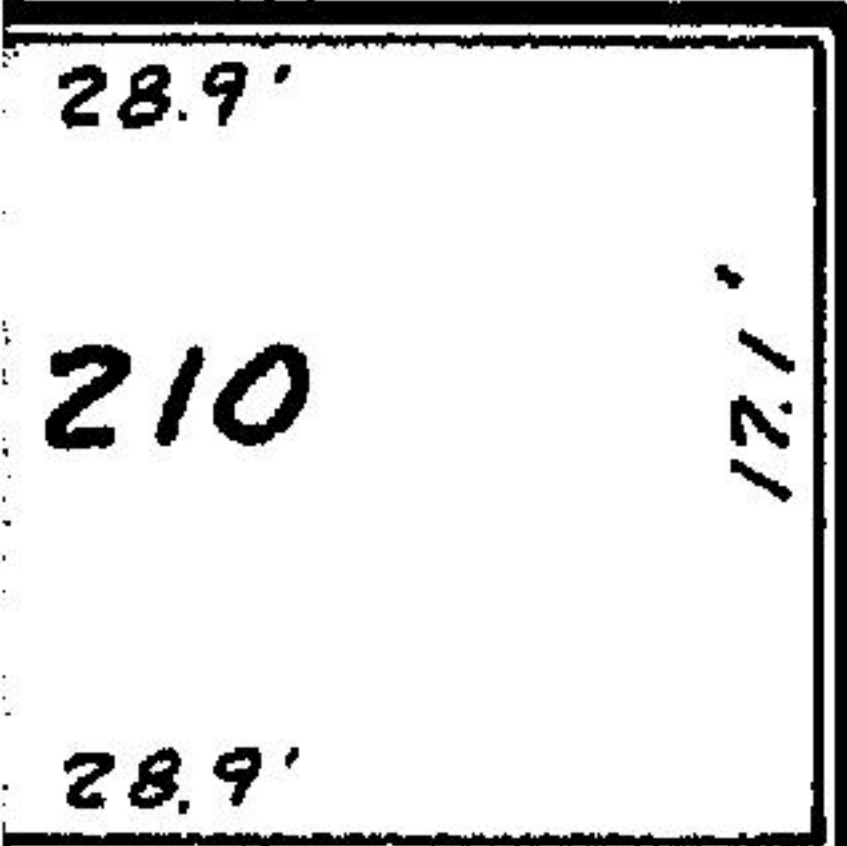

Official Copy

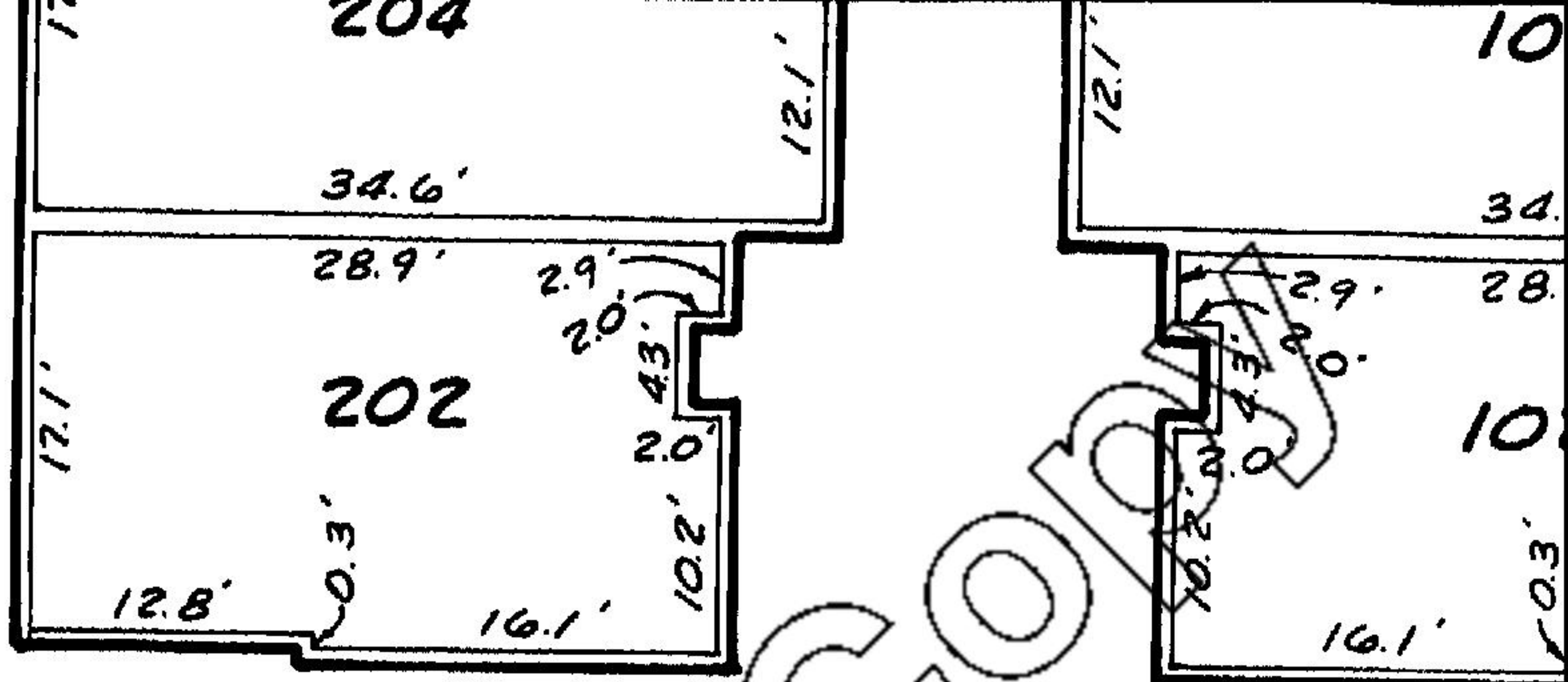

**BUILDING A
FIRST FLOOR**

**BUILDING B
FIRST FLOOR**

BUILDING TABULATIONS

BUILDING LETTER	UNIT NO.	FINISHED FLOOR ELEV. 1ST FLOOR	FINISHED CEILING ELEV. 1ST FLOOR	FINISHED FLOOR ELEV. 2ND FLOOR	FINISHED CEILING ELEV. 2ND FLOOR	UNIT AREA SQ. FT.	% OF OWNERSHIP
A	202	495.78	504.78	505.88	514.88	999.97	9.3580
A	204	495.78	504.78	505.88	514.88	1163.32	10.8870
A	206	495.78	504.78	505.88	514.88	1036.26	9.6980
A	208	495.78	504.78	505.88	514.88	1163.32	10.8870
A	210	495.78	504.78	505.88	514.88	979.78	9.1700
B	102	495.78	504.78	505.88	514.88	999.97	9.3580
B	104	495.78	504.78	505.88	514.88	1163.32	10.8870
B	106	495.78	504.78	505.88	514.88	1036.26	9.6980
B	108	495.78	504.78	505.88	514.88	1163.32	10.8870
B	110	495.78	504.78	505.88	514.88	979.78	9.1700

84046 4460

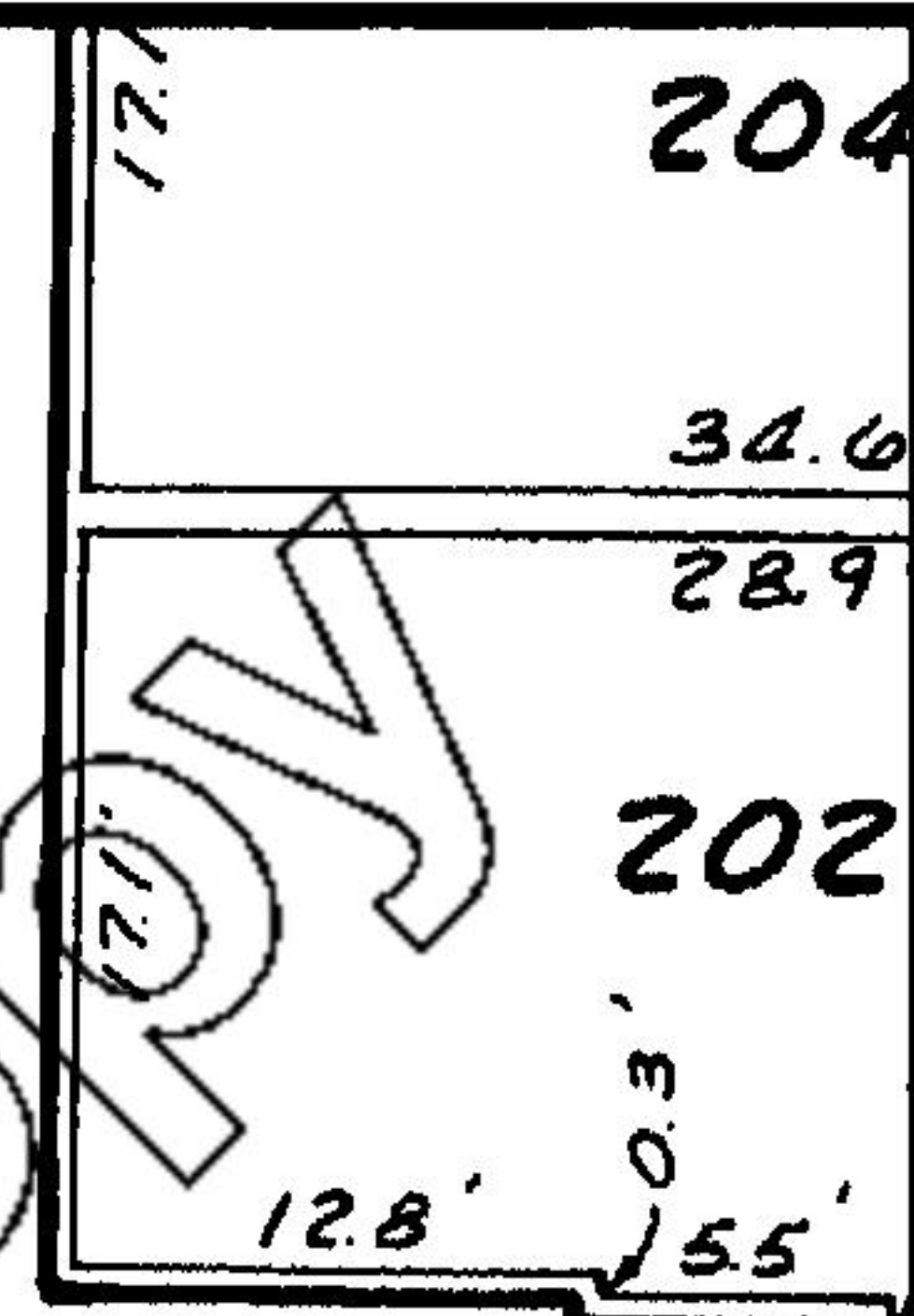
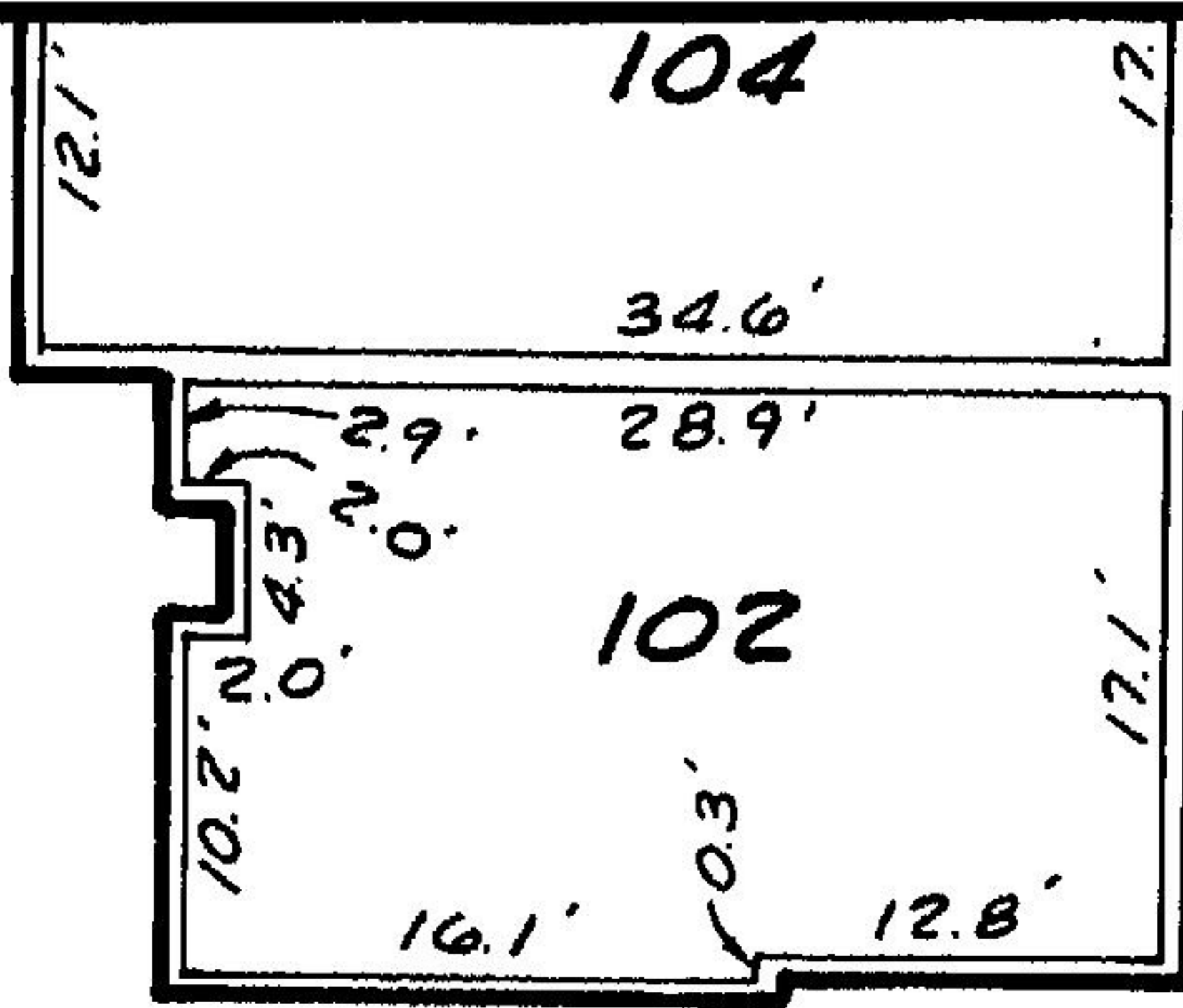

**BUILDING B
FIRST FLOOR**

**BUILDING
SECOND FLOOR**

ABULATIONS

FINISHED CEILING ELEV. 2ND FLOOR	UNIT AREA SQ. FT.	% OF OWNERSHIP	REMARKS
514.88	999.97	9.3580	STUDIO
514.88	1163.32	10.8870	STUDIO
514.88	1036.26	9.6980	STUDIO
514.88	1163.32	10.8870	STUDIO
514.88	979.78	9.1700	STUDIO
514.88	999.97	9.3580	STUDIO
514.88	1163.32	10.8870	STUDIO
514.88	1036.26	9.6980	STUDIO
514.88	1163.32	10.8870	STUDIO
514.88	979.78	9.1700	STUDIO

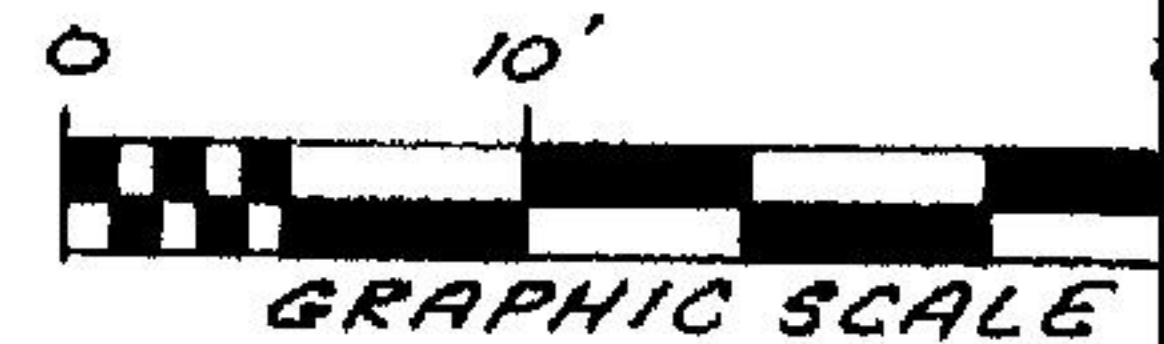

**BILLY
AND
CONS
2
DALL**

84046 4461

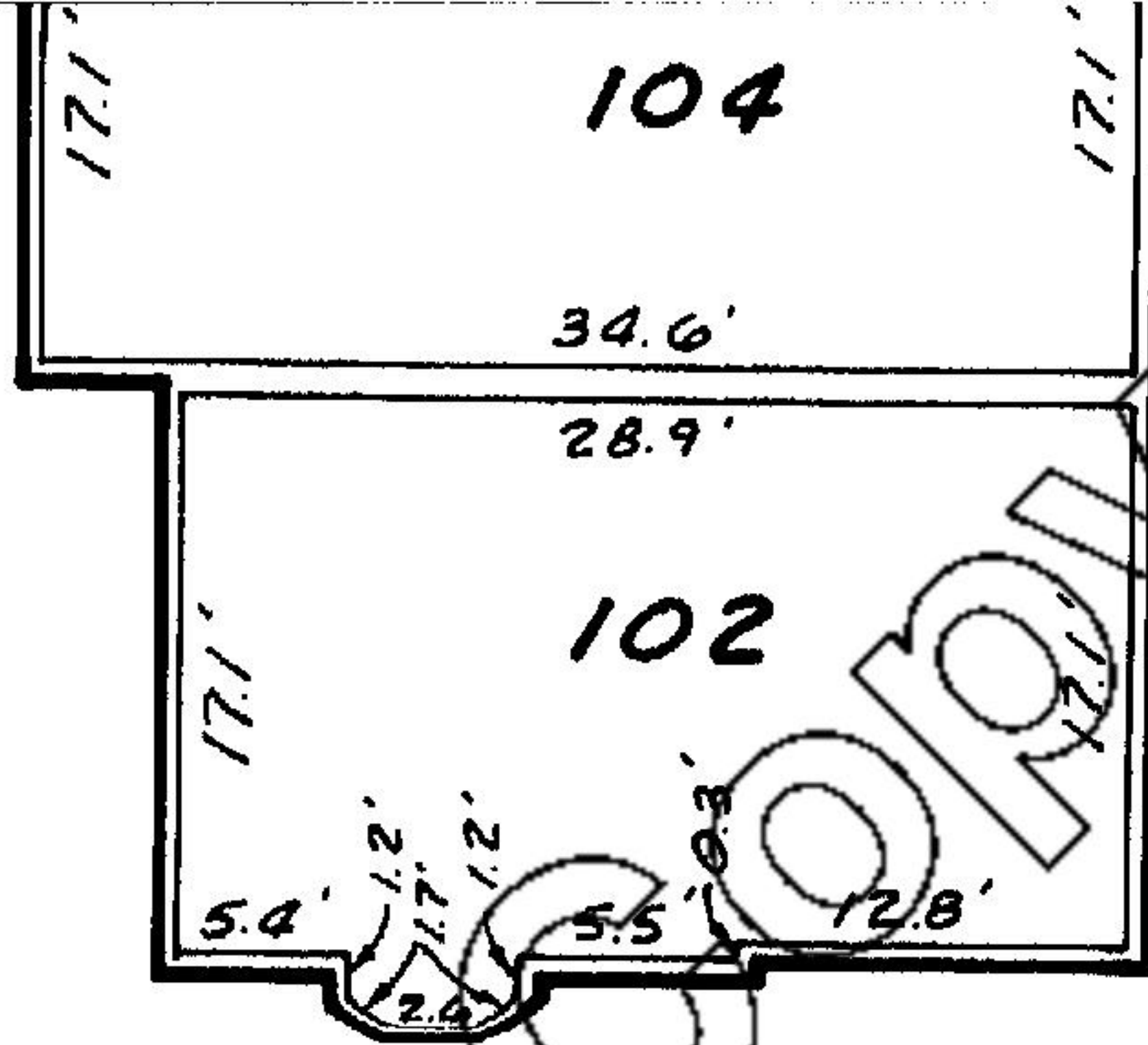
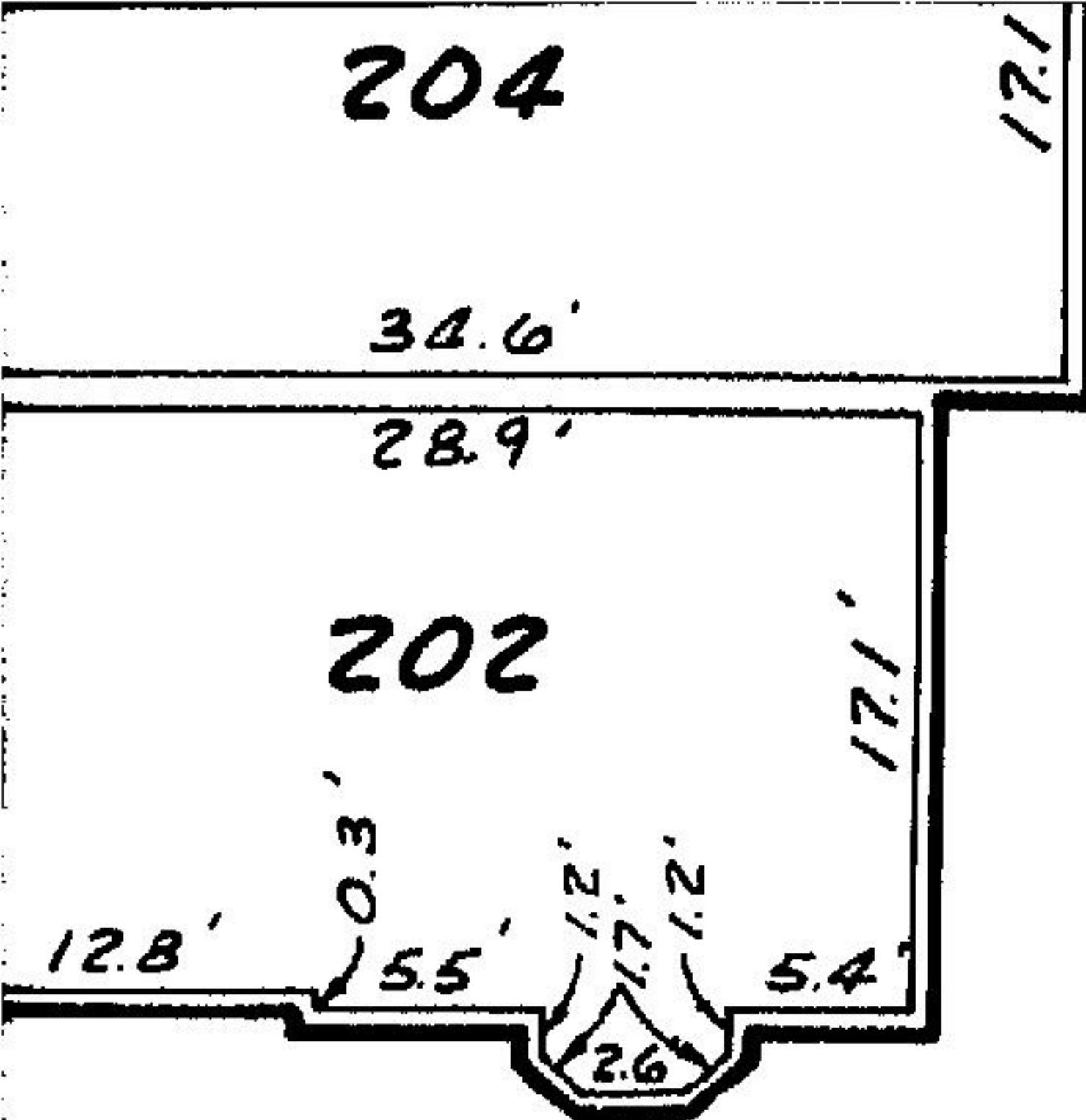

**BUILDING A
SECOND FLOOR**

**BUILDING B
SECOND FLOOR**

NOTE: ALL AREAS OUTSIDE OF UNITS
ARE GENERAL COMMON UNLESS
NOTED OTHERWISE.



EXHIBIT "B"

**BILLY L. STEPHENSON
AND ASSOCIATES
CONSULTING ENGINEERS**
3220 HIGHLAND ROAD
(214) 324-2461
DALLAS, TEXAS 75228

UNIT DETAILS

**HOLLAND OAKS
CONDOMINIUMS**

81046 4462

SHEET NO. 3 OF
SCALE: 1" = 10'
DRAWN BY: D. R.
SURVEYED 10-19
SURVEYED BY D. R.
CHECKED BY: B. L.
JOB NO. 83022

EXHIBIT "C"

HOLLAND OAKS CONDOMINIUMS
PERCENTAGES OF OWNERSHIP INTERESTS

<u>BUILDING LETTER</u>	<u>UNIT NUMBER</u>	<u>PERCENTAGE OF OWNERSHIP</u>
A	202	9.3580
A	204	10.8870
A	206	9.6980
A	208	10.8870
A	210	9.1700
B	102	9.3580
B	104	10.8870
B	106	9.6980
B	108	10.8870
B	110	9.1700
		<u>100.0000%</u>

Unofficial Copy

Unofficial Copy

84 MAR 5 PM 2 06

FILED
Earl Bullock
COUNTY CLERK
DALLAS COUNTY, TEXAS

STATE OF TEXAS COUNTY OF DALLAS
I hereby certify that this instrument was filed on the date and time stamped hereon by me and was duly recorded in the volume and page of the named records of Dallas County, Texas as stamped hereon by me.

MAR 6 1984



Earl Bullock
COUNTY CLERK, Dallas County, Texas

Mary Beal
Plano Title Company
701 15th Street
Plano, Texas 75074

WHEN RECORDED RETURN TO:

4944 84046